

Flush Channel

The Node Flush Channel is designed to be mounted flush with the ceiling plane. The Flush Channel locates all Node devices as part of a coordinated solution for lighting and other building services. The Node Flush Channel can be provided in a wide variety of finishes to suit any ceiling design.

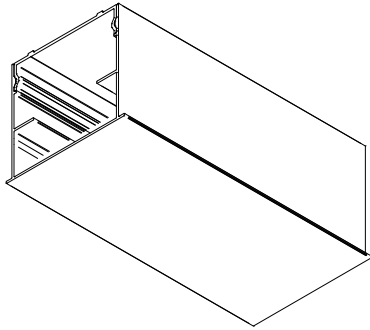

Product Features

- Easy installation
- Compatible with a wide range of available Node devices
- Removable face for device accessibility
- Factory coordinated device locations
- Mounting compatibility with Weave Radiant Textile Panels and other popular ceiling finishes
- Extruded trough with alignment features for adjacent channel sections

Specifications

Dimensions

- Width - 4.72in./120mm
- Overall Height - 4.33in./110mm
- Maximum Length per Section - 118.11in./3000mm
- Weight - 0.19lbs/in. [3.39kg/m]

Configurations

- Straight Length
- End Condition
- 90 Degree Perpendicular Non-Mitered Junctions

Finish

- Powder coat black
- Powder coat white
- Anodized black
- Anodized clear
- Anodized champagne
- Anodized light bronze
- Anodized medium bronze
- Anodized dark bronze