

node

## Flush Channel Installation Guide



**NODE FLUSH CHANNEL INSTALLATION GUIDE**

v002

© 2020 Price Industries Limited o/a PARC. All rights reserved.

**TABLE OF CONTENTS**

Product Overview ..... 2

Read and Save These Instructions ..... 4

Before You Start ..... 4

Tools Required ..... 4

Site Conditions, Storage and Handling Instructions ..... 4

Installation ..... 5

    Installing to CORE ..... 6

    Installing to Push Latch/Magnet Mounting ..... 8

    Installing to Other ..... 10

    Installing Channel Face ..... 12

Connecting Node Flush Channels ..... 13

End Caps ..... 15

Cutting Node Flush Channels to Length on Site ..... 16

Node Device Installation ..... 16

Node Device Removal ..... 16

Waste Disposal Management ..... 17

## Flush Channel Installation Guide

### Product Overview

Node Flush Channel is an architectural extruded aluminum channel that integrates various building services such as lights, sprinklers, speakers, etc. Node Flush Channel can be ordered in any increment between 250mm to 3000mm. Channel sections can be spliced together to make up a run longer than 3000mm. A product overview of the channel is shown below.

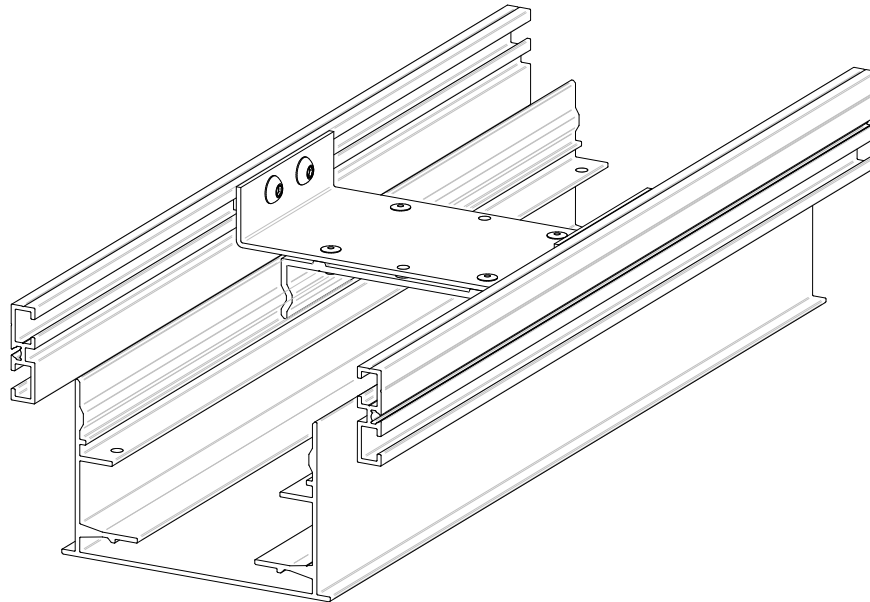

Figure 1: Node Flush Channel Assembly

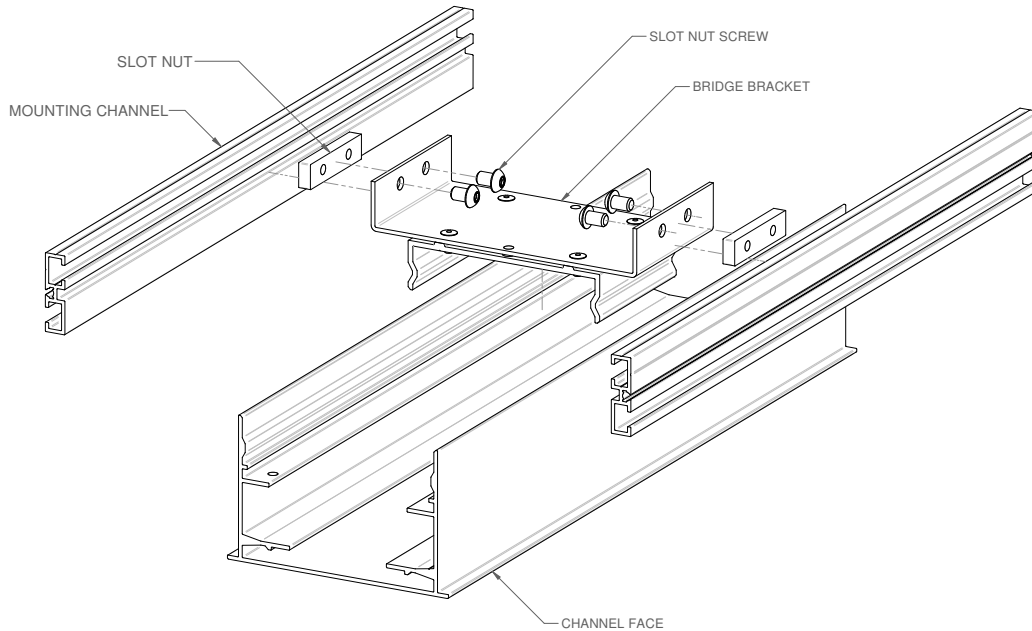
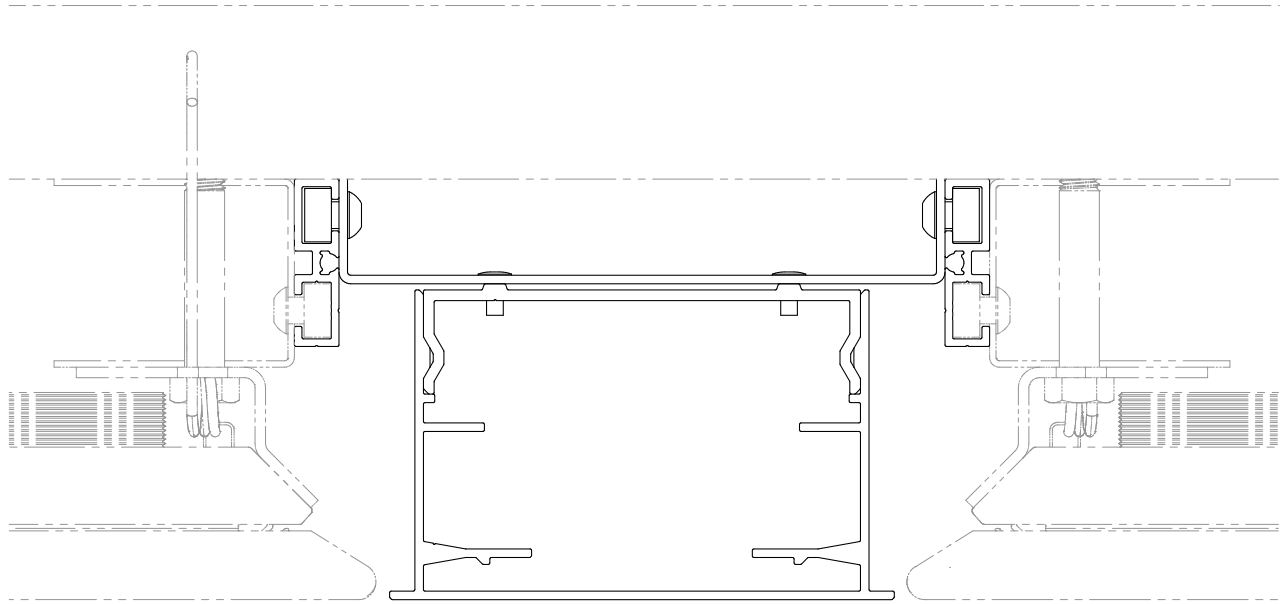

Figure 2: Node Flush Channel - Component View

Node Flush Channel is designed to be installed in ceilings with recessed voids in addition to ceiling panels or plasterboard on either side of the channel.



**Figure 3: Node Flush Channel Installed Assembly**

The following guide should only be used for Node Flush Channel where PARC is not providing the diffuser or plenum. Please refer to our Node Flush Channel with Diffuser Installation Guide if you are installing with the Node Flush Diffuser.

For Node installation to Core, please refer to the Core installation manual for information on how to install Core. This manual assumes the relevant Core pieces are already installed in the appropriate positions.

It is recommended that the Node Flush Channel length is coordinated with the manufacturer to the required sizes to match the building design. The Node Flush Channel can be site cut if required.

The Node devices are supplied separately from the channel assemblies.

**Note:** *All mounting hardware and sub structure is to be supplied and installed alongside the Node Flush Channel.*

*Lighting and other services must be installed by qualified personnel.*

For further information regarding product or installation, please contact [info@parc-ceilings.com](mailto:info@parc-ceilings.com).

## Flush Channel Installation Guide

Read and save these instructions before beginning to install the Node Flush Channel.

**Warning!** To reduce the risk of fire, electric shock, or injury to persons, observe the following:

- When cutting or drilling into wall or ceiling do not damage electrical wiring and other hidden utilities
- Use this unit only in the manner intended by the manufacturer. If you have any questions, contact the manufacturer [info@parc-celings.com](mailto:info@parc-celings.com).

### Before You Start

Inspect all product parts for flaws and shipping damage.

If anything is discovered to be damaged, contact the shipping company and manufacturer immediately.

**Warning! Damaged or missing parts must be reported to PARC at [info@parc-ceilings.com](mailto:info@parc-ceilings.com) immediately, PARC will not be responsible for any damage or loss that occurs during unpacking or installation.**

### Tools Required



### Site Conditions, Storage and Handling

Read this guide before handling the product.

- **Read the Installation Guide before handling.**
- **Always wear appropriate hand protection when handling.**
- **Only store in clean dry conditions.**
- **Do not over stack.**
- **Do not stack in a way likely to cause falls.**

Poor or rough handling, rolling or dropping of the product on corners or edges may cause damage to the product or cause the product to deteriorate.

Lengths of Node should not span between points as any load applied mid-span may cause product damage.

Site storage of items should be flat, preferably on a suitable pallet (supporting the entire length of the Node Flush Channel) without additional top loading.

Consideration should be given to the advice of the Site Occupational Health and Safety Representative regarding manual handling. An assessment should be made of any risk and if necessary mechanical lifting equipment should be used.

The storage space must be cleared of debris and, in general, should be enclosed. The Node Flush Channel should be kept clean, dry and protected from the elements.

Site conditions should be prepared for installation of the Node Flush Channel. The site should be clean, dry and clear of other trades working in the ceiling void.

**Installation**

Node Flush Channel is designed to either mount with Core (a PARC product) or Push Latch/Magnet Mounting system. Custom mounting, to suit other ceiling panel installations, is available and should be specified at the project planning stage. Please refer to the project submittal if a custom mounting system is specified.

The Node Flush Channel installation sequence begins by installing the mounting channel and bridge bracket sub assembly into the ceiling, followed by pushing the channel face onto the snap feature of the bridge bracket. The primary mounting feature of the mounting channel is the outer mounting slot, which is used for Core and Other mounting solutions. Note: The Push Latch/Magnet Mounting does not use the mounting channel.

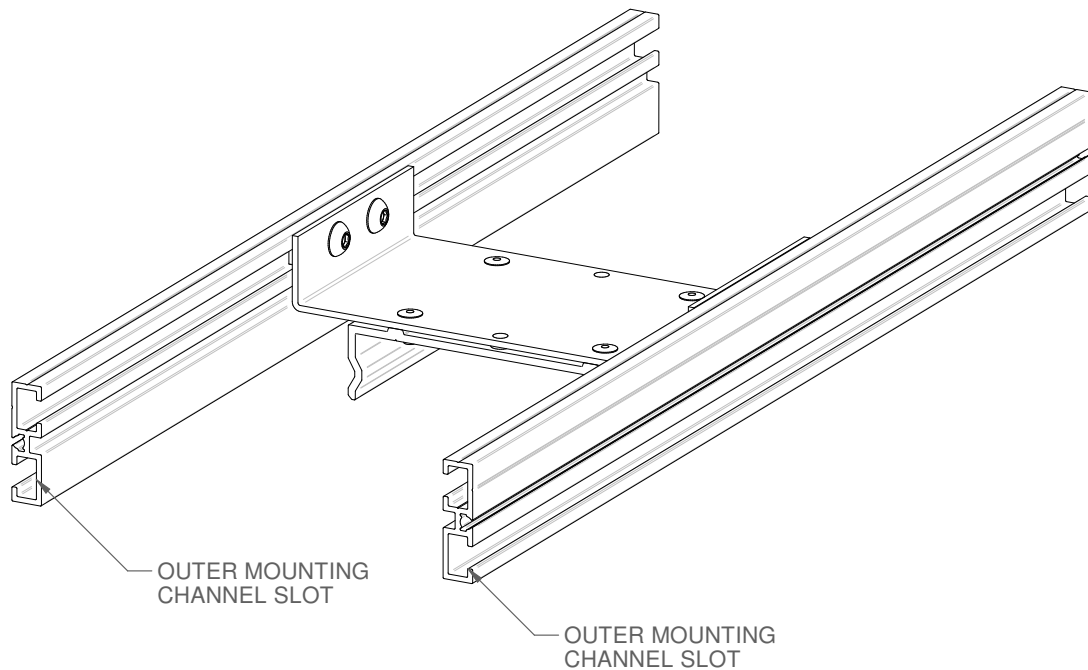

**Figure 4: Mounting Channel & Bridge Bracket Sub Assembly**

Please refer to sections Installing to Core, Installing to Push Latch/Magnet Mounting and Installing to Other for information on how to install the mounting channel and bridge bracket sub assembly. Please refer to the Installing to Channel Face section for information on installing the channel face into the bridge bracket.

## Flush Channel Installation Guide

### Installing to CORE

Flush Channel mounting installs to Core through C-brackets. C-brackets are installed with Core and the brackets should exist in the ceiling space at the time of Node Flush Channel installation. For additional information please consult the Core installation manual.

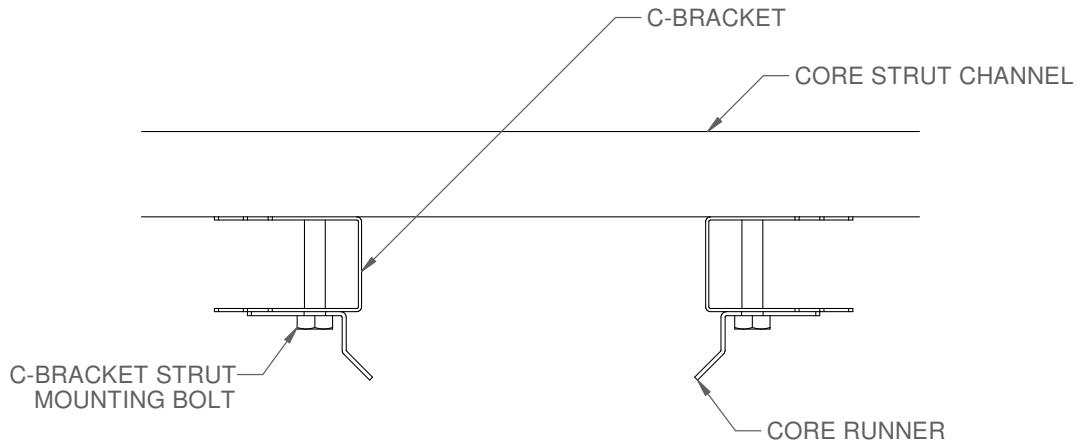

Figure 5: Elevation view of Core mounting system

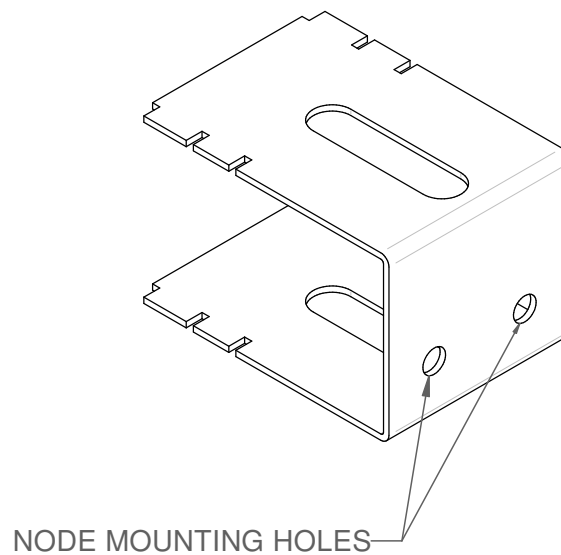
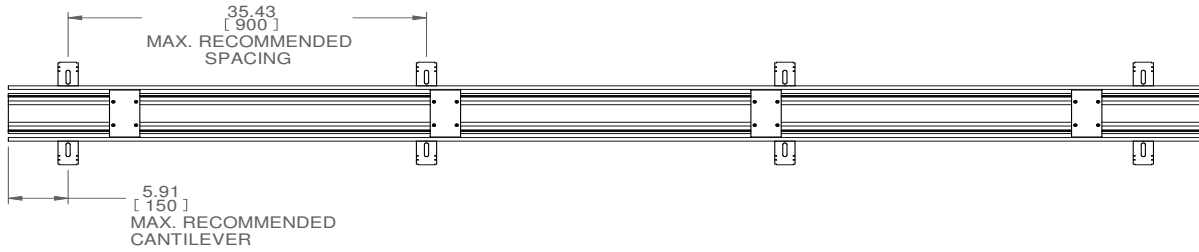

Figure 6: C-Bracket

First, ensure the spacing between C-brackets on the Core runners is 900mm or less. If 900mm or more exists between 2 C-brackets that were installed with Core, an additional C-bracket shall be installed onto the Core runner. Refer to the guide below on spacing of C-brackets.

## Flush Channel Installation Guide



Next, slide provided slot nuts into the outer mounting channel slot of the mounting channel, one for every C-bracket. Fasten provided screws into each Node mounting hole on the C-bracket with a 4mm or 3/32" hex driver.

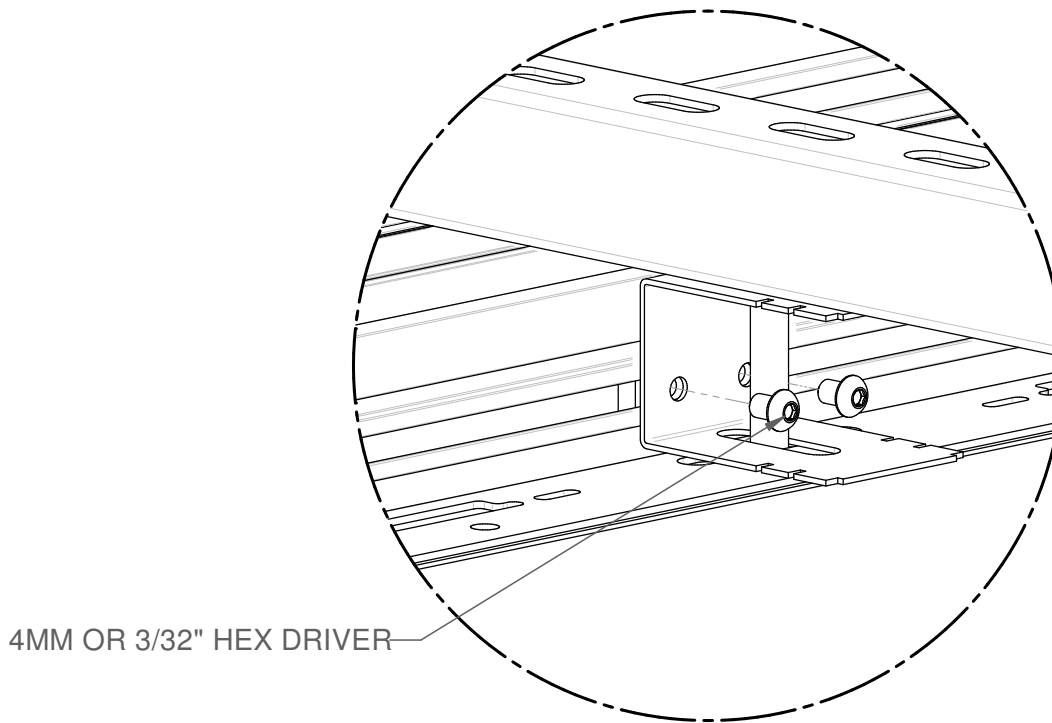

Figure 7: C-Bracket Mounting Detail

Final installation of the mounting channel and bridge bracket assembly shall match the following. Ensure line and level of subassembly.



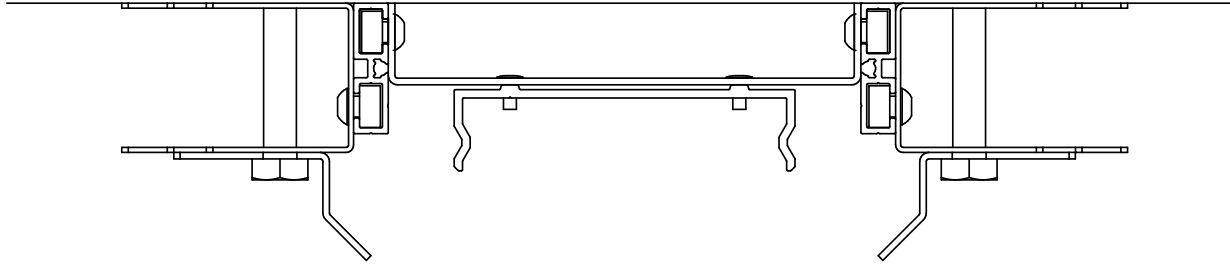

Figure 8: Node subassembly installation to Core

### Installing to Push/Magnet Mounting

Installation to the Push Latch/Magnet Mounting system uses a bridge bracket mounting plate secured directly to the strut channel. This manual assumes the Push Latch/Magnet Mounting system is installed in the ceiling already. Note: this system does not use the mounting channel.

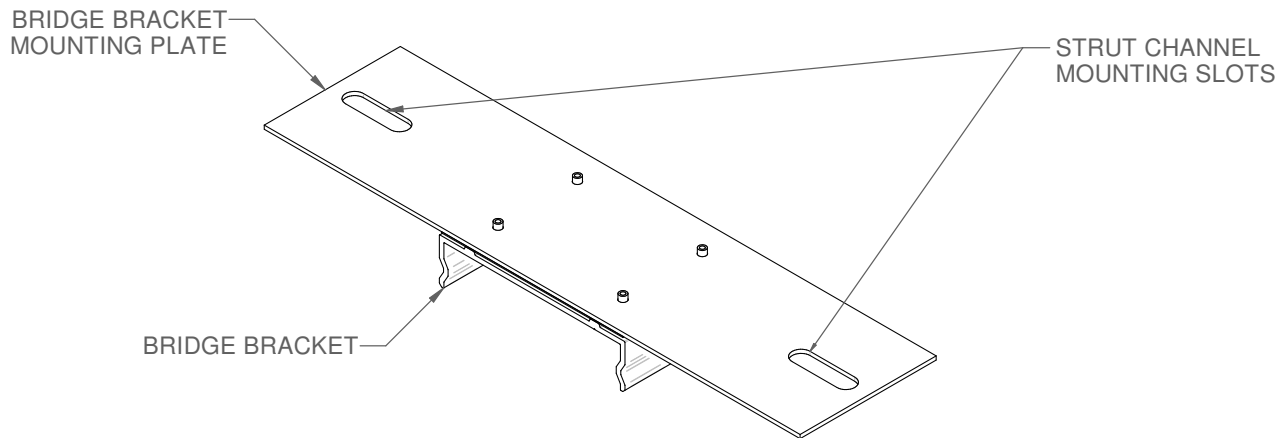

Figure 9: Bridge bracket for Push Latch/Magnet Mounting ISO View



Figure 10: Bridge bracket for Push Latch/Magnet Mounting Front View

To install, simply place the bridge bracket mounting plate on top of the strut channel and fasten through the slots. Fasteners are not provided by PARC.

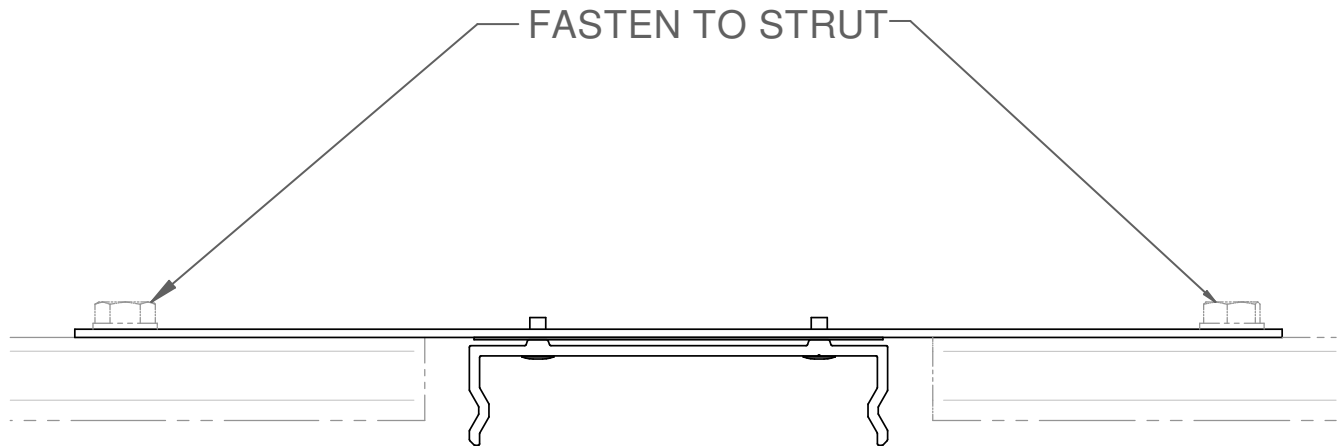

Figure 11: Bridge bracket mounted to strut channel

Horizontal adjustments can be made to ensure the linearity between bridge brackets. Bridge brackets that are out of line can cause issues when installing the channel face.

Final installation of the bridge brackets shall match the following.

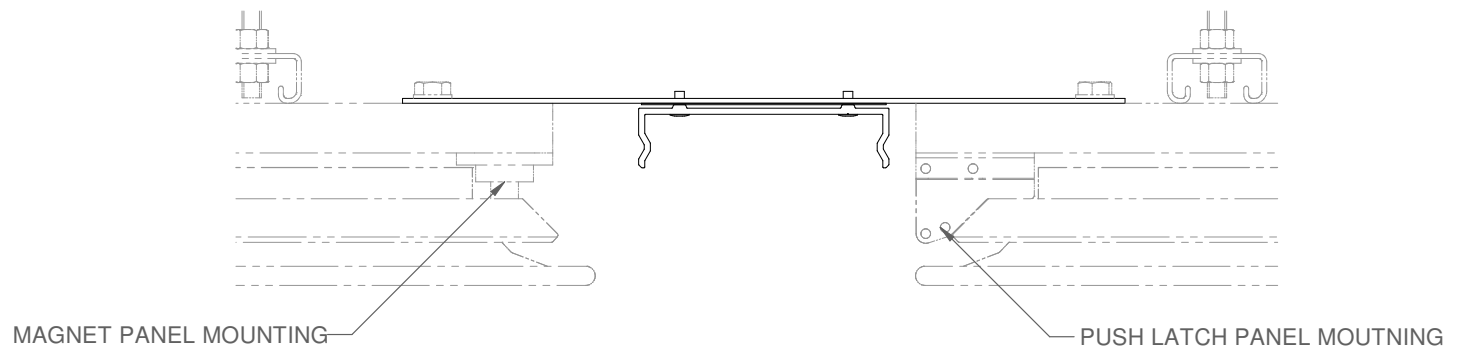

Figure 12: Push Latch/Magnet Mounting final assembly

Installing to Other

When installing the Node Flush Channel by other means, the custom mounting brackets can either be provided by PARC or provided by others. Additionally, the slot nuts can be provided by PARC or by others. Information to aid in the design of brackets and/or slot nuts is shown in the image below.

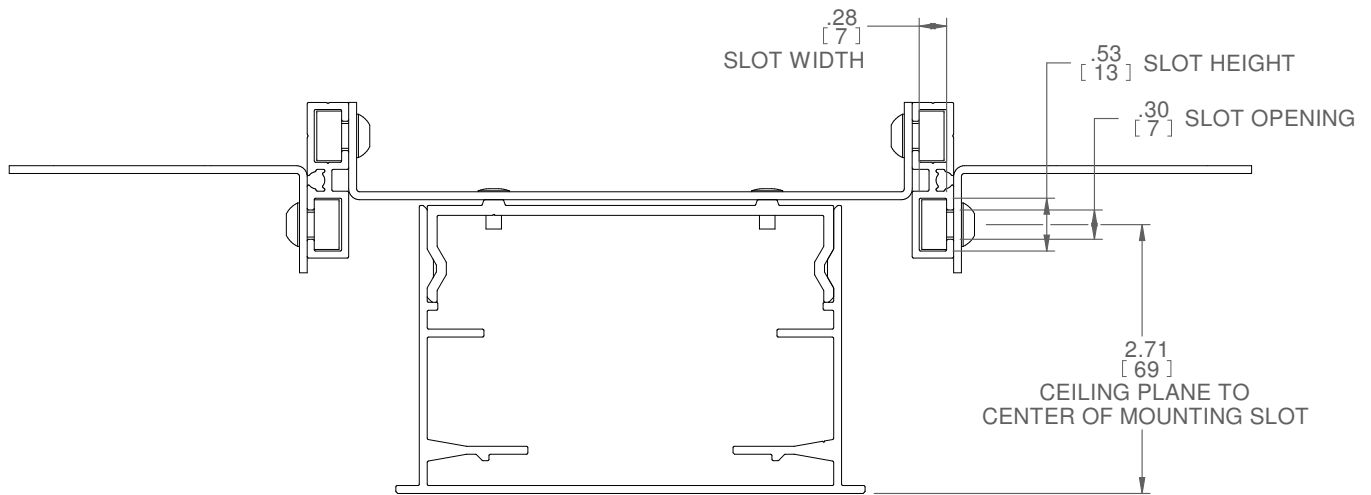

Figure 13: Mounting dimensions for other installations

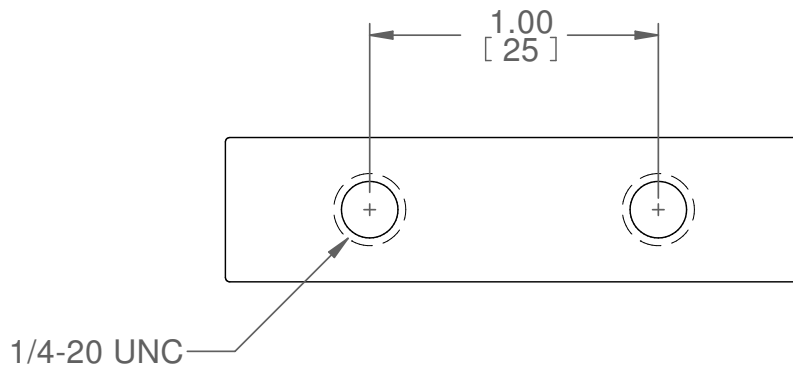

Figure 14: Slot nut dimensions

When using PARC slot nuts, slide the custom mounting bracket into place and secure with specified fastener.

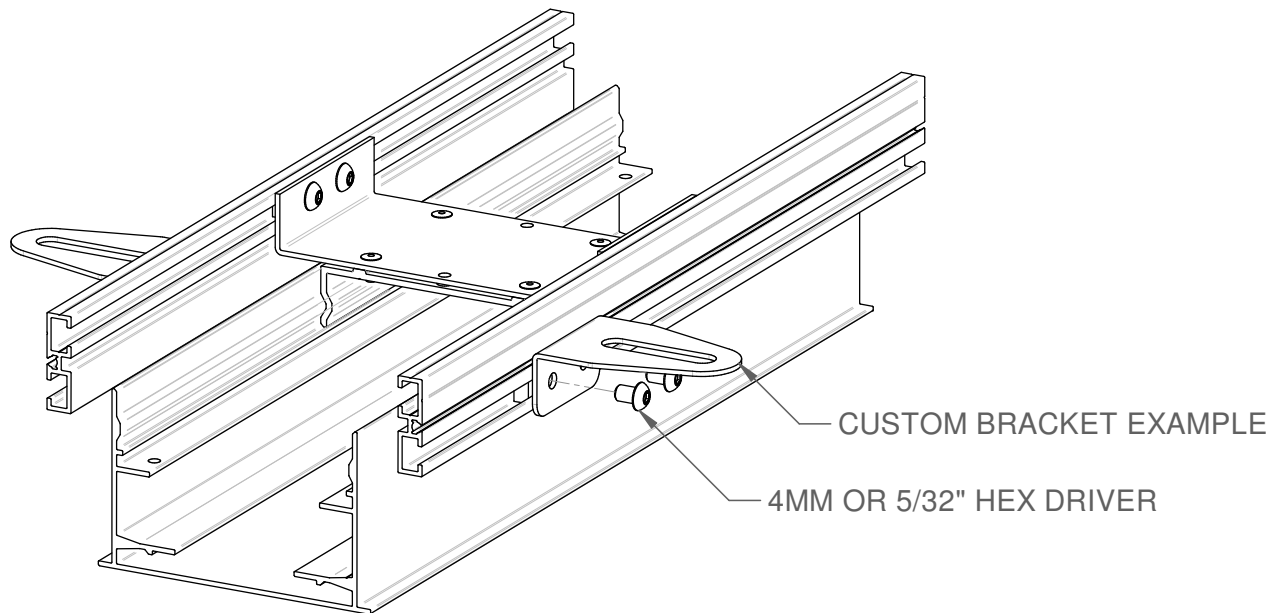

Figure 15: Installation of custom brackets

Bracket spacing recommendations follow the image below.

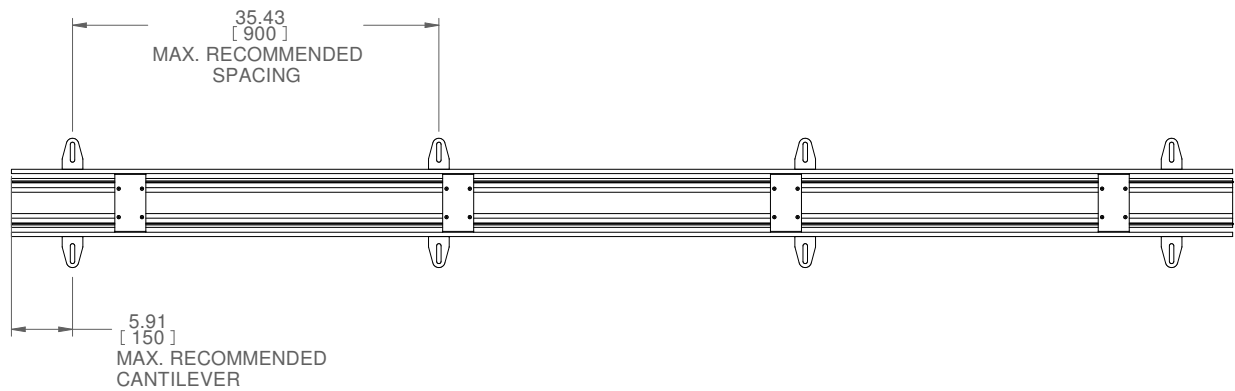

Figure 16: Recommended spacing for mounting brackets

Finish installation by mounting brackets to the ceiling by project specific details.

## Flush Channel Installation Guide

### Installing Channel Face

Channel face installation follows the mounting channel and bridge bracket installation. To install the channel face, first install the access cables between the channel face and the bridge bracket.

The channel face and bridge bracket have factory drilled holes on either end of each component. Hook the access cable through these provided holes to make the connection. If the hole location on the channel is not sufficient, a hole can be drilled at any location on the indicated surface, per the detail view below. A minimum of 2 access cables are required per channel.

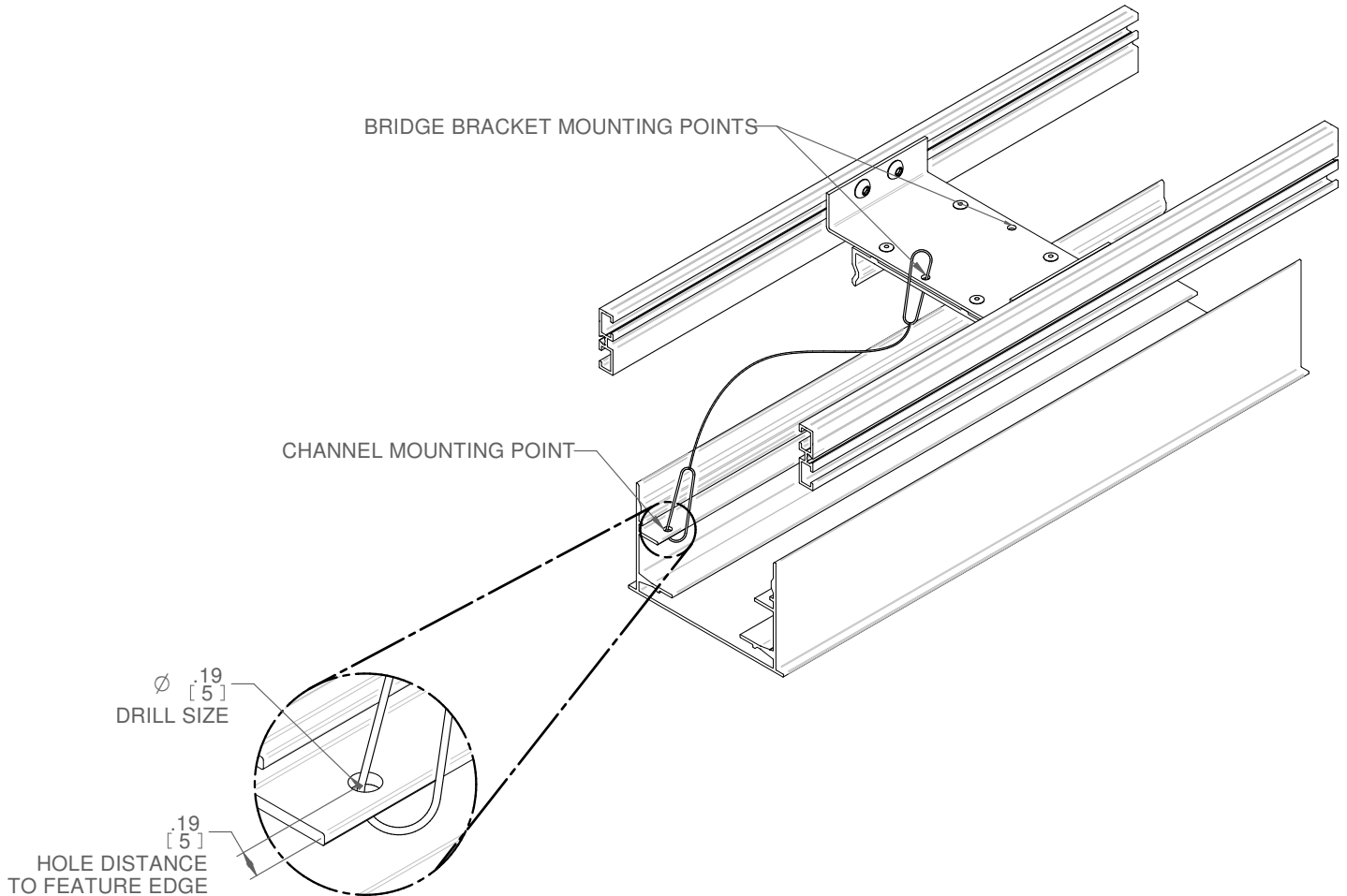

Figure 17: Access cable installation detail

Following the installation of the access cables, complete the installation carefully by pushing the channel face into the bridge bracket until you hear a click.

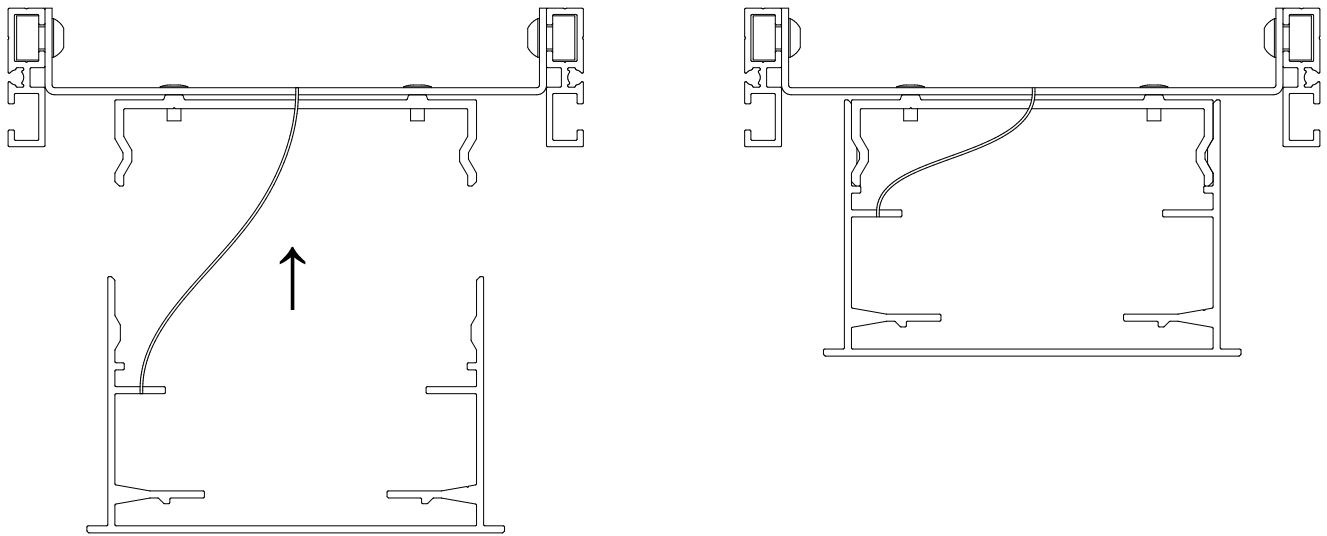

Figure 18: Flush channel face installation

### Connecting Node Flush Channels

Node Flush channels can be connected by way of a provided plastic alignment clip. Alignment clips should be used to ensure a high-quality joint between adjacent channel faces. When the mounting channel is provided, install a slot nut on both sides of the mounting channel per Figure 19, to further reinforce the alignment.

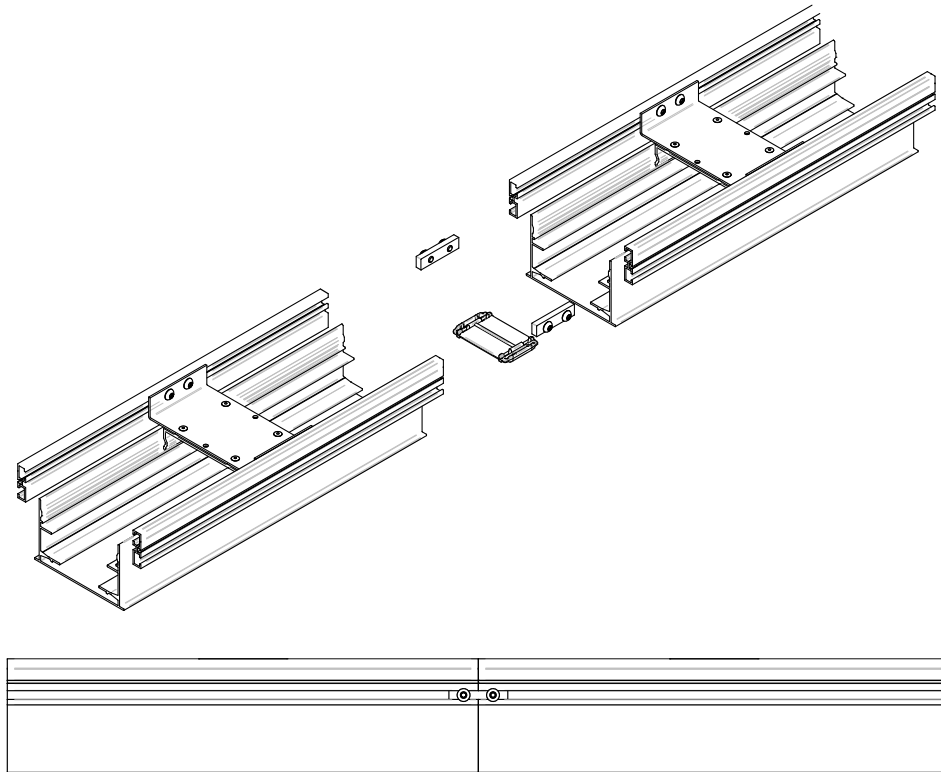

Figure 19: Flush channel with mounting channel splice connection

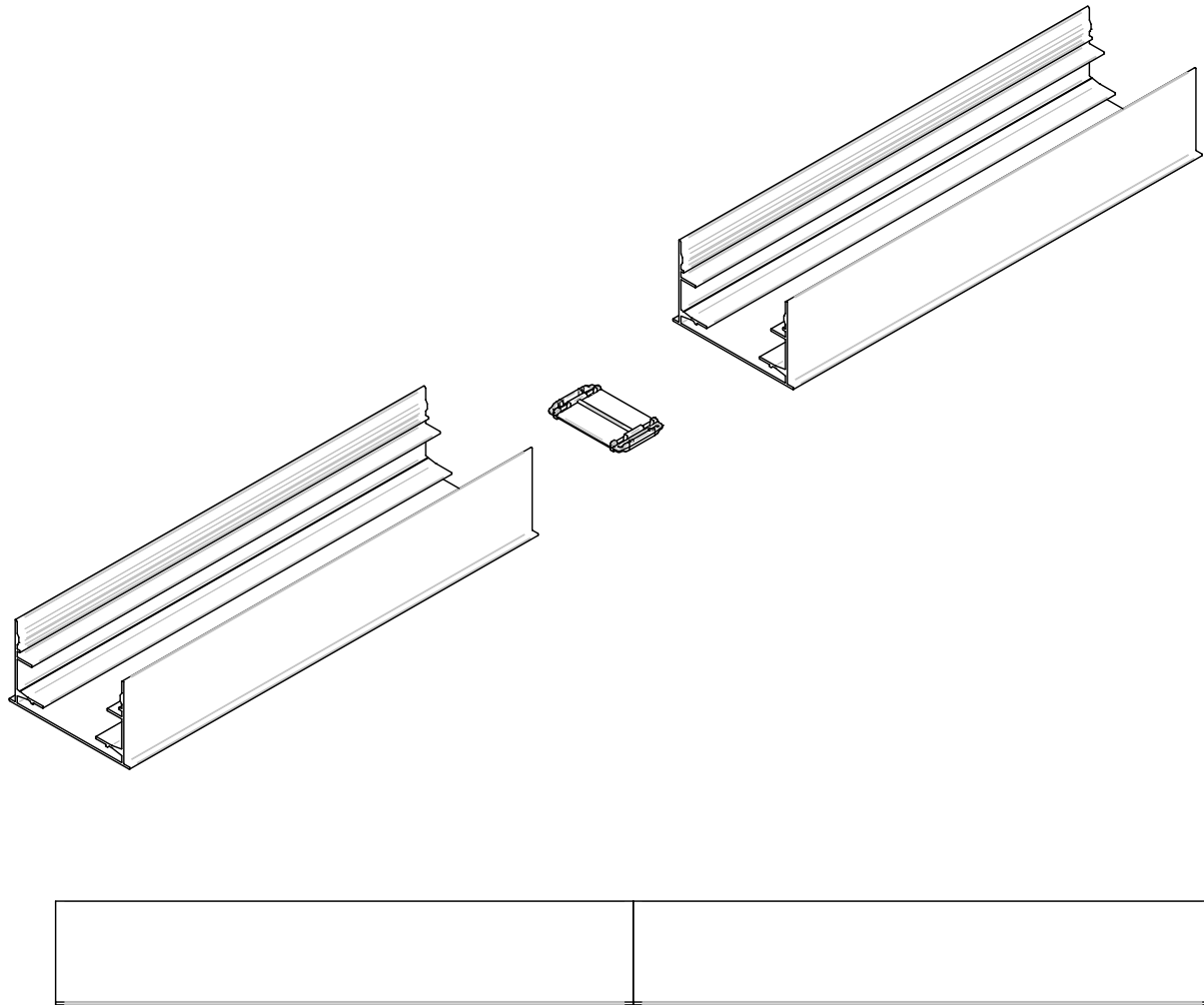

Figure 20: Flush channel splice connection

Connect all required sections, ensuring no visible gap between both sections.

Note: it may not be possible to install the plastic alignment clip on sections that terminate next to a wall. In these situations, the alignment clip can be omitted from the installation.

### End Caps

The Node Flush Channel can be provided with or without end caps as per project design requirements. End caps are factory installed as required.

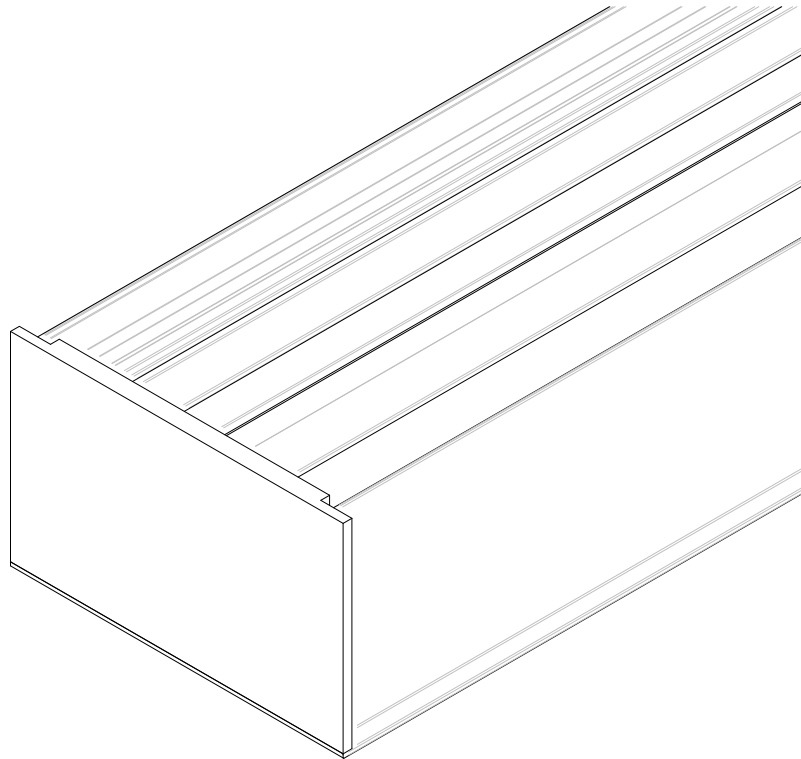

Figure 21: Flush channel end cap



## Flush Channel Installation Guide

### Cutting Node Flush Channels to Length

Where possible, the channel should be ordered to length based upon contractor site measurements.

Since end caps are factory installed and welded in place, cutting channels to length is not recommended where end caps have been selected. If the channel must be cut to length, this should be done at the end, rather than a joint, to minimize visual impact. The maximum length that can be trimmed is defined by the position of the bridge bracket.

### Node Device Installation

Node devices can be integrated into the system at design stage and can be purchased separately from the Node Channel.

Outer Node housings will be factory installed in the required locations.

The Node devices are installed in the housing by aligning the snap tabs and pushing the inner casing directly into the housing.

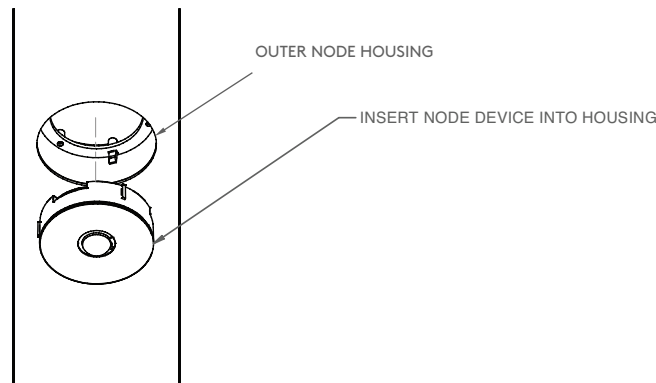

Figure 22

### Node Device Removal

To remove the Node device, insert the Node removal tool, supplied by PARC, into the shadow gap between the outer housing and device. Slide the Node removal tool anti-clockwise until the Node device is released.

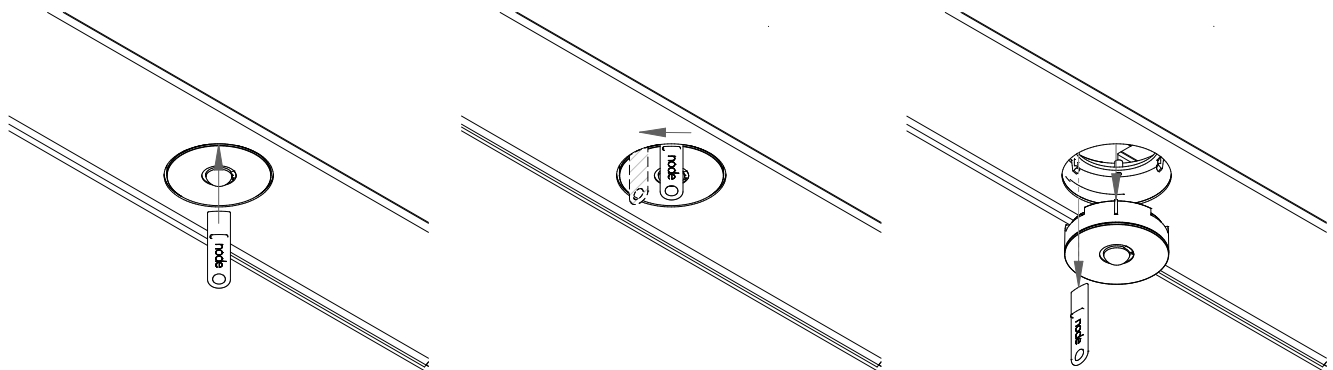

Figure 23

**Waste Disposal Management**

PARC Node Channels are shipped and packaged with protective material that should be disposed of in an appropriate manner. Please remove or recycle waste and packaging materials as per your local waste disposal requirement.



The information contained in this document only provides guidance for the installation of PARC products. All PARC products should only be installed by trained professionals and installation responsibility remains with the installer.

PARC reserves the right to review, alter, amend or remove publish data without notice as our policy is one of constant improvement. The information contained in this installation guide is believed to be correct at the date of publication. Whilst PARC will endeavor to keep its publications up to date, reader will appreciate that between publications there will be changes in laws or other developments affecting the accuracy of the information contained in this installation guide.