

INSTALLATION GUIDE: Weave Radiant Textile Panel Featuring Core Mounting System

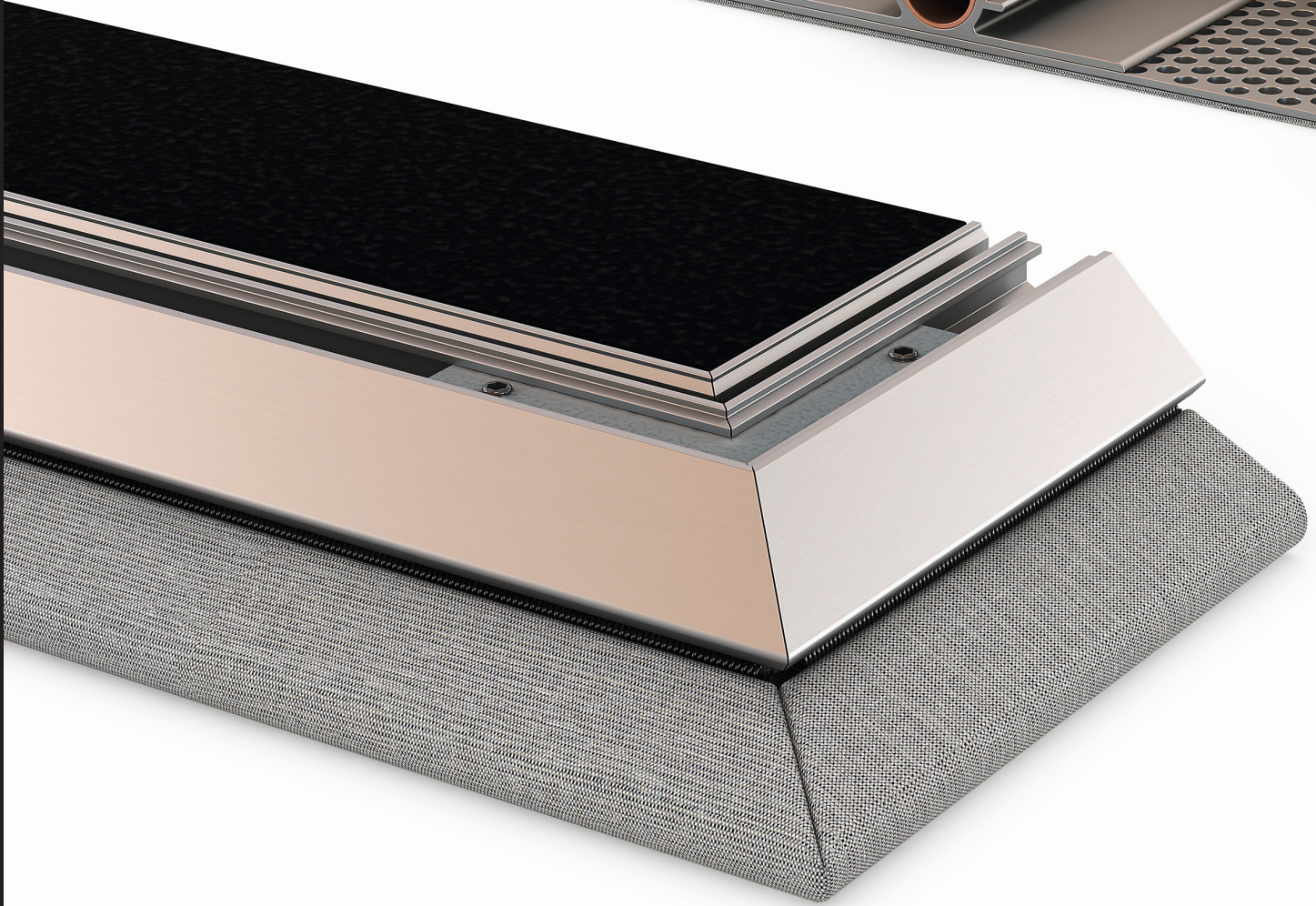
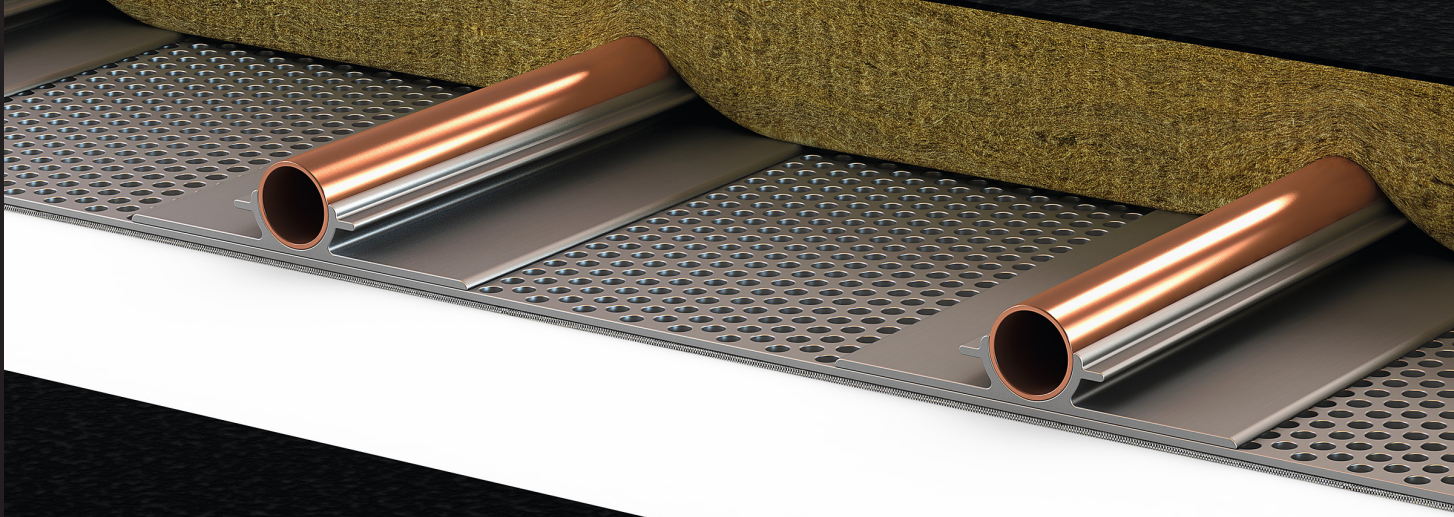

weave™

v005

Product Overview

Weave Radiant Textile Panels are upholstered in Kvadrat textiles to provide colour and texture options for seamless integration with any design scheme. Capable of both heating and cooling, Weave can be applied to most spaces.

Typical applications include office buildings, schools and public buildings.

For further information regarding product or installation, please contact ceilings@Lindner-Group.com.

FIG. 1: ISO VIEW

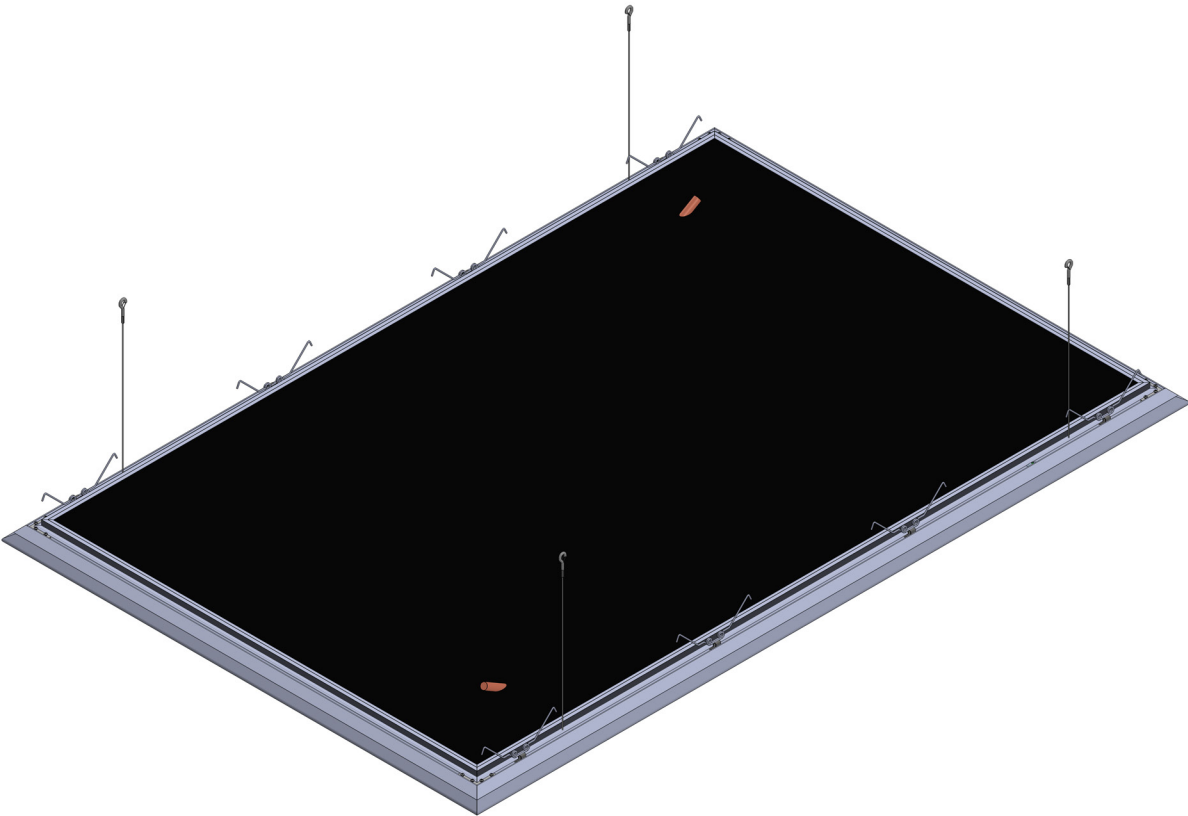



WARNING!

Read and save these instructions before beginning to install Weave Radiant Textile Panels.

To reduce the risk of fire, electric shock, or injury to persons, observe the following:





- When cutting or drilling into wall or ceiling, do not damage electrical wiring and other hidden utilities.
- Use this unit only in the manner intended by the manufacturer. If you have any questions, contact the manufacturer or Lindner PARC Technical Support.
- When installing Weave Radiant Textile Panels, a team of at least two installation technicians is required.
- Torsion spring tips could pierce skin if not handled with caution.
- Drain system prior to removing panels.
- Keep hands away from torsion springs and pinch points when pushing a panel up into the installed position.

Before You Start

Inspect all product parts for flaws and shipping damage.

If anything is discovered to be damaged, contact the shipping company and manufacturer immediately.

Tools Required

 6' level	 Laser level	 Measuring tape
 3/8" / 10mm socket or wrench		

Site Conditions, Storage and Handling

- Read the Installation guide before handling.
- Always wear clean, nonabrasive gloves when handling panels.
- Only store in clean dry conditions.
- Store upright and face to face.
- Do not remove protective plastic wrap on textile until panel is installed in ceiling.
- Reference the tags and labels associated with each panel and component.
- Do not place panels on their corners.
- Do not over stack.
- Do not stack in a way likely to cause falls.

Poor or rough handling, rolling or dropping of the product on corners or edges may cause damage to the product or the product to deteriorate.

Consideration should be given to the advice of the Occupational Health & Safety Representative regarding manual handling. An assessment should be made of any risk and if necessary mechanical lifting equipment should be used.

The storage space must be cleared of debris and, in general, should be enclosed. The Weave Radiant Textile Panels should be kept clean, dry and protected from the elements.

Installation of Weave panels will require a minimum of at least two installation technicians.

Weave Panel Installation to Core

For detailed information on installing the Core system, please refer to the Core installation manual.

Step 1: Positioning Torsion Springs on Panel

The first torsion spring on a panel can be located using the adjacent wall. Measure the distance from the center of the runner slot to the wall. Calculate the distance to the first spring with the equation below.

FIGURE 2: FIRST TORSION SPRING MEASUREMENT

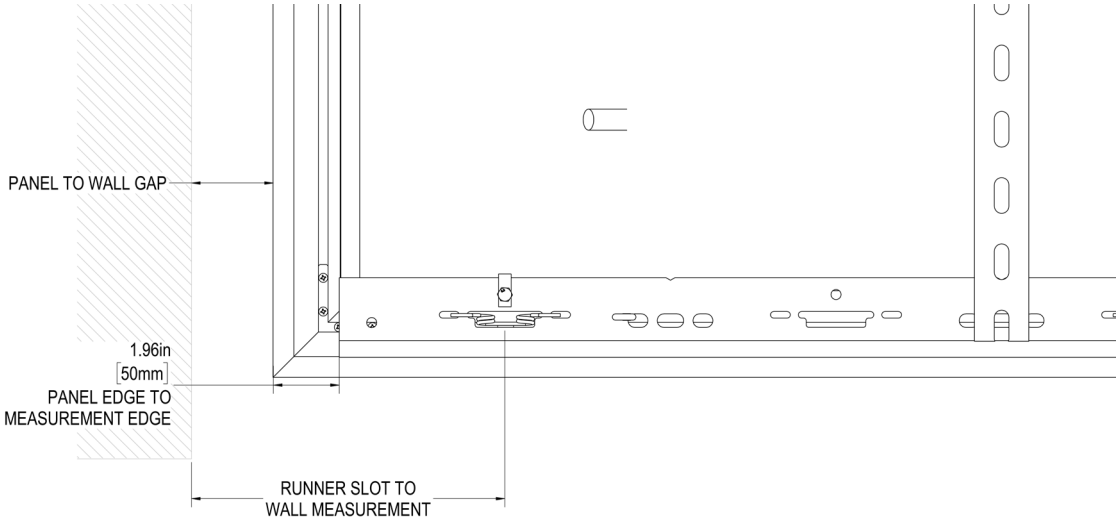

$$\text{Calculated distance to first spring} = \text{Runner slot to wall measurement [mm]} - 50\text{mm} - \text{panel to wall gap [mm]}$$

FIGURE 3: CALCULATED DISTANCE TO FIRST SPRING

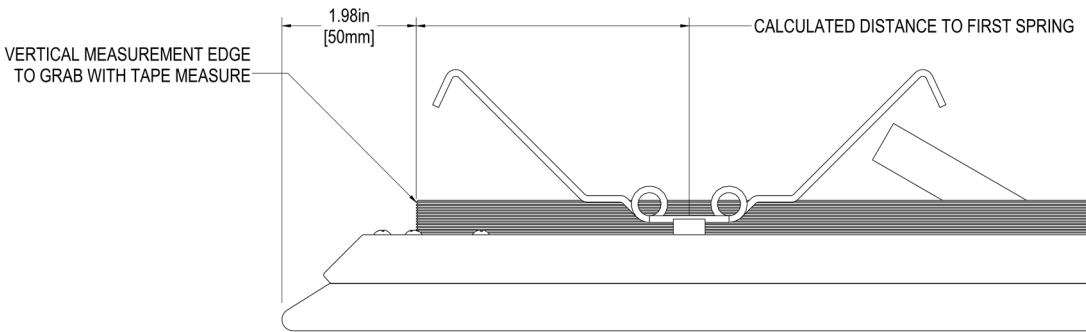

An even number of torsion springs is required on both sides of the panel. The first torsion spring should be placed no further than 250mm from the edge of the Weave panel, and no distance between 2 torsion springs can be greater than 1500mm.

FIGURE 4: MAXIMUM DISTANCES BETWEEN TORSION SPRINGS

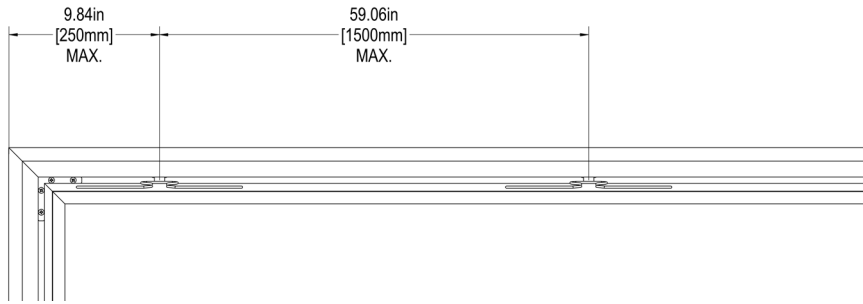

The Core runners have slots for torsion springs every 250mm

FIGURE 5: CORE RUNNER TOP VIEW

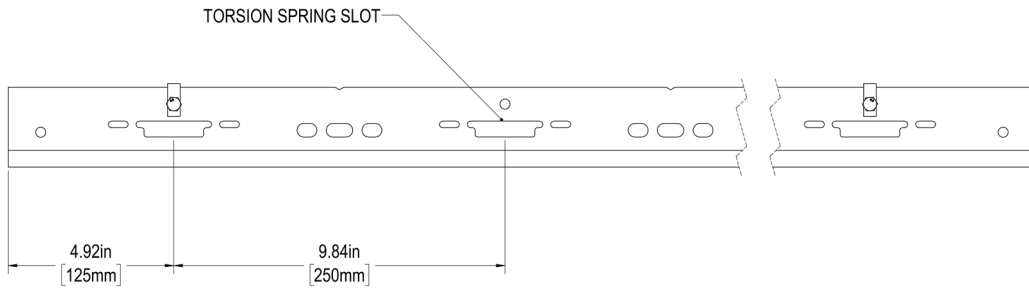

The minimum number of torsion springs per panel is listed per the chart below:

FIGURE 6: MINIMUM NUMBER OF TORSION SPRINGS PER PANEL

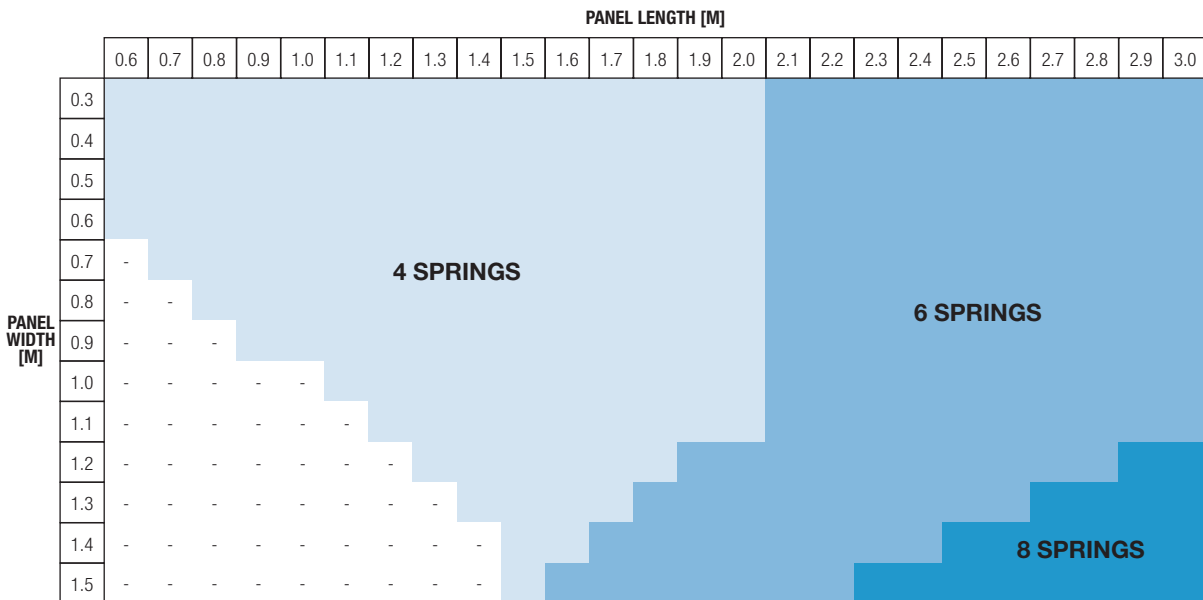

Step 2: Positioning Torsion Springs on Panel

To install the torsion spring onto the panel, place the torsion spring foot on the spring as shown below:

FIGURE 7: TORSION SPRING AND TORSION SPRING FOOT

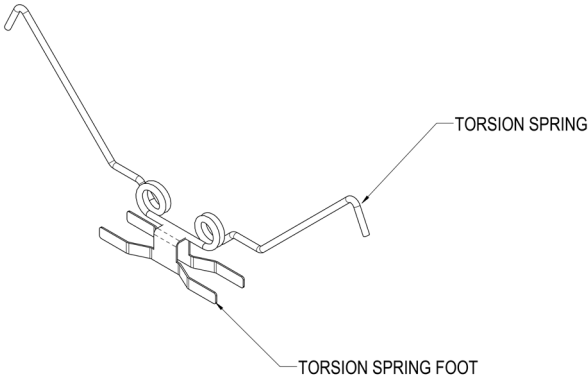

To install the torsion spring foot, place one side in the Weave channel and apply pressure from the other side towards the slot.

FIGURE 8: TORSION SPRING INSTALLED INTO PANEL

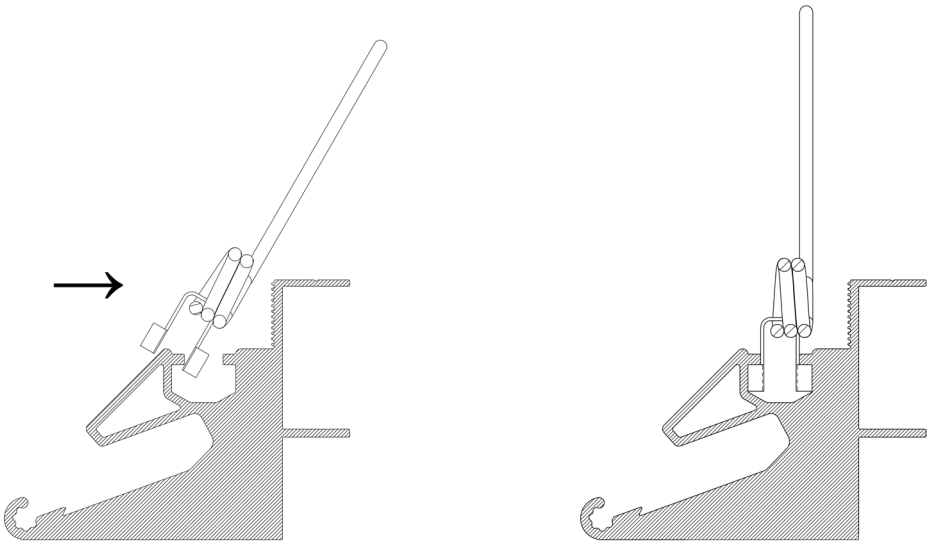

Ensure all 4 legs are inside the channel and secured in place.

Note, the torsion spring must be installed with the loops of the spring on the outside edge of the Weave panel, shown below.

FIGURE 9: CORRECT INSTALLATION OF TORSION SPRING (LEFT), INCORRECT INSTALLATION OF TORSION SPRING (RIGHT)

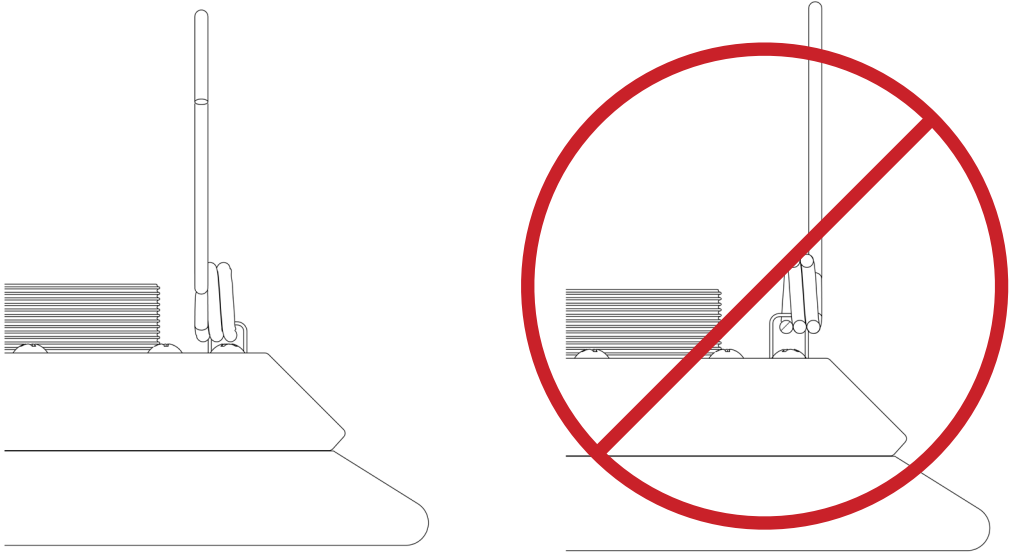

Step 3 – Attach Access Cables

Access cables come pre-installed in the Weave panel. If adjustments are required, loosen the screw and slide along the profile.

FIGURE 10: ACCESS CABLE LINEAR ADJUSTMENT

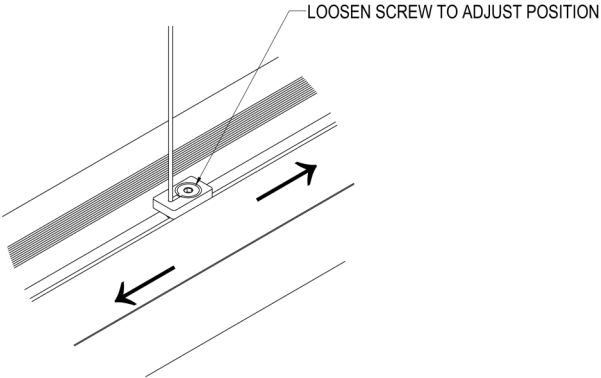

A minimum of 4 access cables are to be used, located in the corners of the Weave panel.

FIGURE 11: ACCESS CABLE LOCATION EXAMPLE

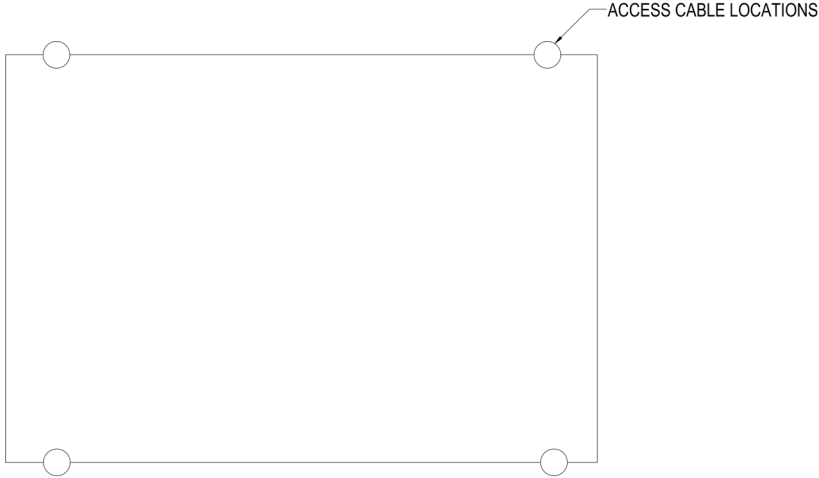

Using the provided access cables, clip each cable to a corresponding mounting slot in the Core runner.

FIGURE 12: ACCESS CABLE CONNECTED TO CORE RUNNER

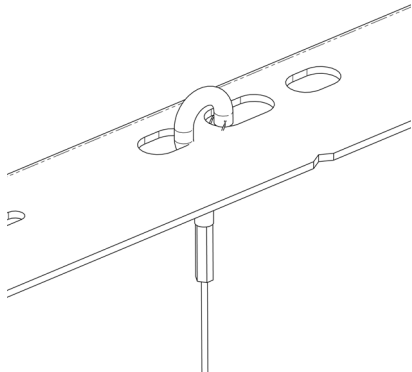

Ensure that the access cable wire is fully latched onto both the Panel Bracket and the Core substructure.

FIGURE 13: WEAWE PANEL SUSPENDING FROM ACCESS CABLES

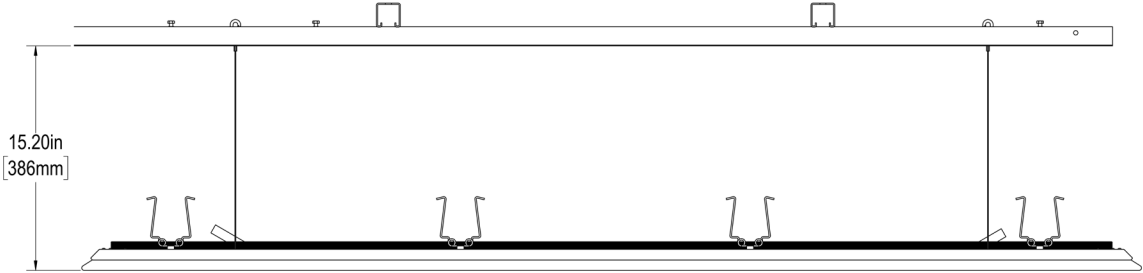

Step 4 – Make Flex Hose Connections

The panel-to-panel and panel-to-header hydronic circuits are connected using the flex hoses provided and should be connected in accordance with the hydronic layout drawings.

To connect the hoses, push the hose all the way onto the end of the copper tubing.

FIGURE 14: HOSE INSTALLATION

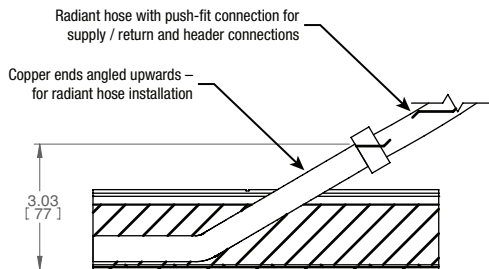
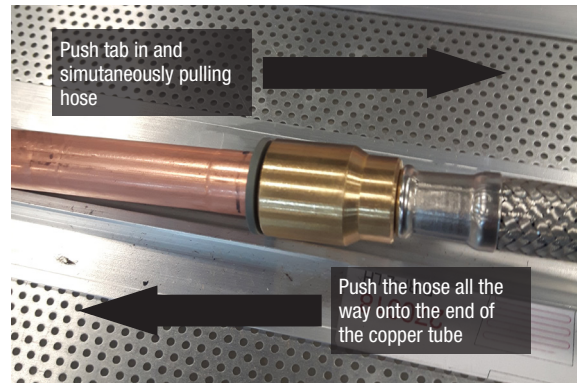

FIGURE 15: HOSE ENGAGEMENT



The other end of the hose must be pushed all the way onto the main, header or adjacent panel by a qualified person.

To release the hose, push the release tab in while simultaneously pulling the hose off.

NOTE: Never remove hose without first checking that system has been drained.

The flex connection hose connection is 5/8 in. (15.875 mm) OD actual.

Step 5 – Connect Torsion Springs to Core Runner

To install the torsion spring, compress the two legs together to fit within the torsion spring slot.

FIGURE 16: COMPRESS TORSION SPRING LEGS TOGETHER

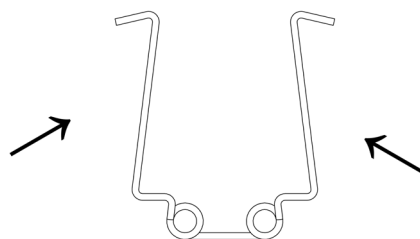

Insert torsion spring into torsion spring slot one leg at a time.

FIGURE 17: INSTALLING TORSION SPRING INTO CORE RUNNER

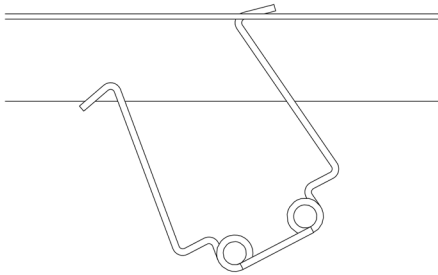
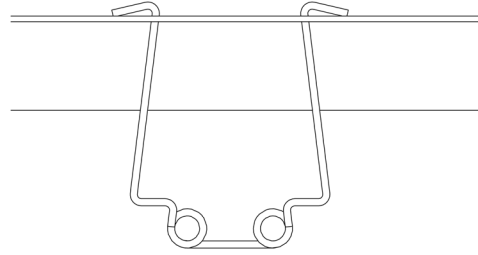

FIGURE 18: TORSION SPRING INSTALLED IN DROP POSITION



Once all torsion springs are attached to Core, push the panel up by its edges into the mounted position, until the Weave panel engages with the Core Runners.

FIGURE 19: PUSHING PANEL INTO CORE RUNNER

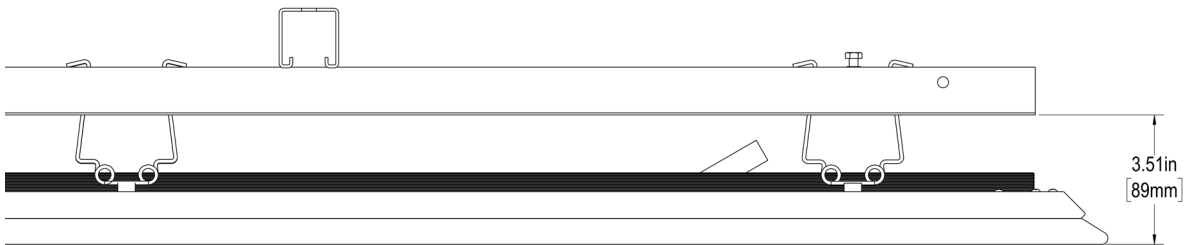
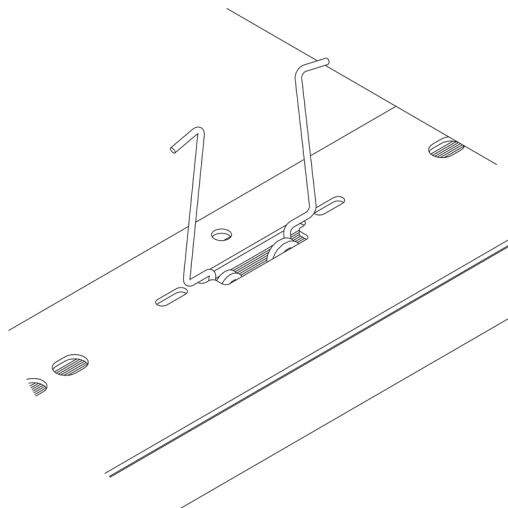
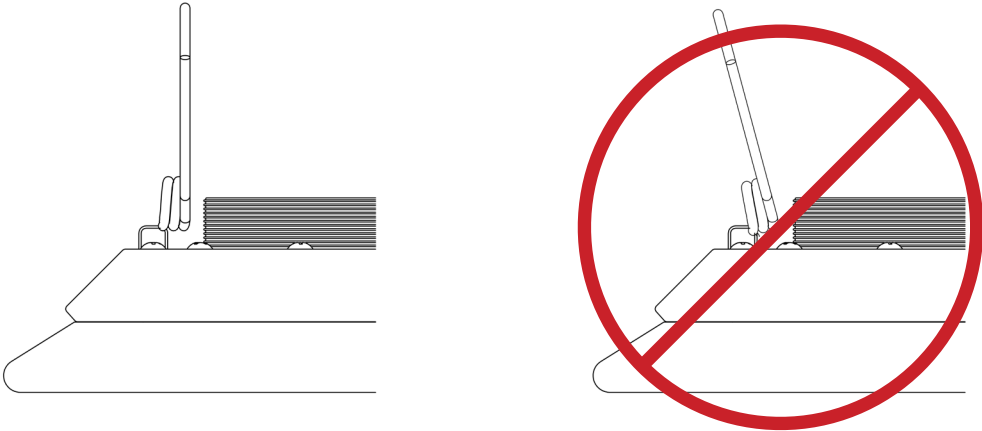

FIGURE 20: ISO VIEW OF INSTALLED TORSION SPRING



Ensure that the springs sit vertically and are not angled to the left or right.

FIGURE 21: LEFT IS CORRECT INSTALLATION, RIGHT IS INCORRECT INSTALLATION



Adjusting planar height of panels

Bolt and clip nuts come installed on the Core runners.

To adjust the planar height of the Weave panel, rotate the bolt clockwise to lower the panel and counter-clockwise to raise the panel. Ensure adjacent Weave panels are planar to one another.

FIGURE 22: VERTICAL ADJUSTMENT CAPABILITIES WITH PLANAR ADJUSTMENT BOLT

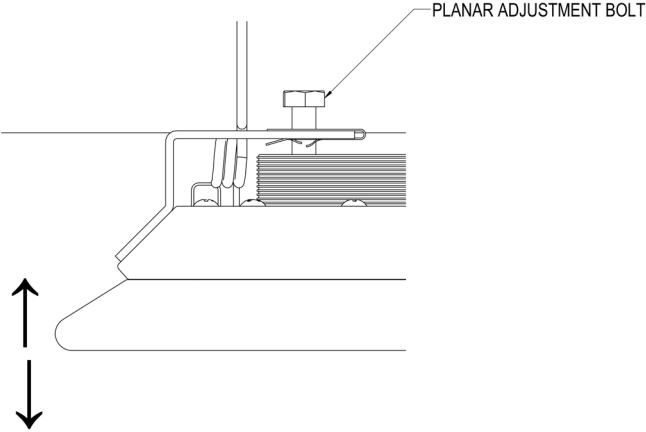

Step 5 – Installation of End Caps (If applicable)

End cap brackets shall be installed directly to Weave panel using the provided hardware. Where Core runners are present, install the end cap brackets to Core using the provided hardware.

FIGURE 23: END CAP BRACKET PANEL MOUNTED

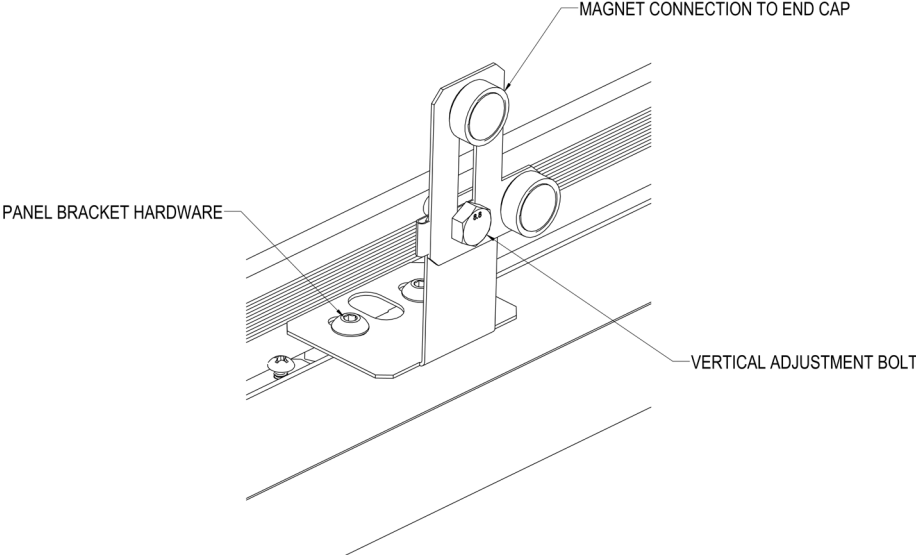
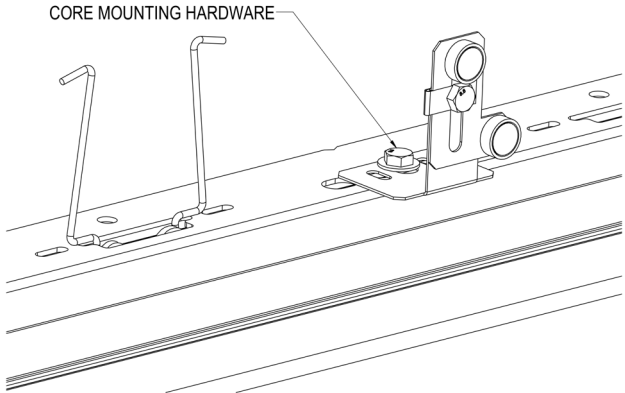

FIGURE 24: END CAP BRACKET CORE MOUNTED



To install the end cap, place the end cap hanger bar on the end cap bracket. The magnets will hold the end cap in position.

FIGURE 25: END CAP INSTALLED

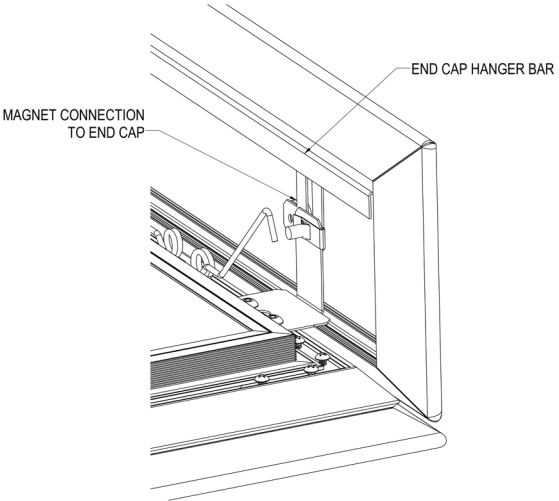
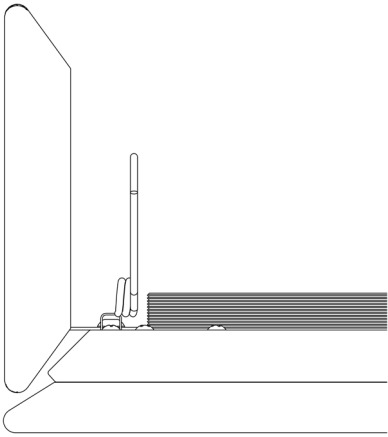

FIGURE 26: END CAP SIDE VIEW



Panel Removal and Hinging Capabilities

NOTE: Do not remove any panels without first checking that the system has been drained and it is safe to do so.

NOTE: A minimum of two technicians required to remove panels.

To remove a panel from its mounted position, gently pull down on two corners.

FIGURE 27: PULLING DOWN EDGE OF PANEL

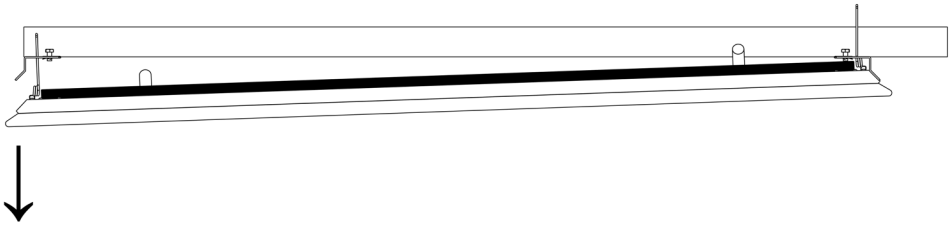

Pull down from the other edge so the panel is in its hanging position.

FIGURE 28: PANEL IN HANGING POSITION

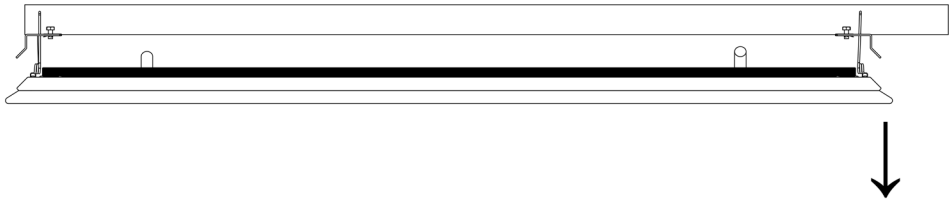
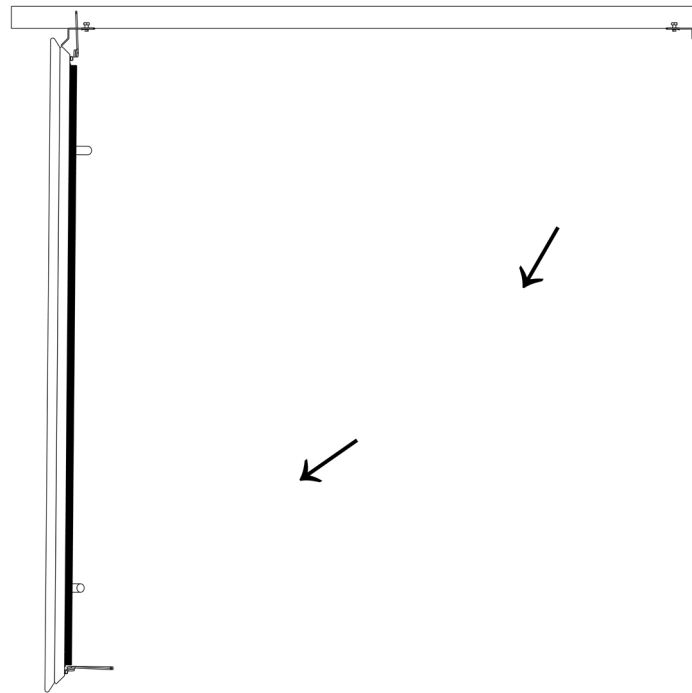

FIGURE 29: PANEL HINGING 90°



Ensure that the access cables are correctly installed before removing the torsion springs.

Remove the torsion springs along one side of the Core runner by compressing the torsion springs and removing them from the receiving slots.

Disconnect the access cables on disconnected side of the panel and gently lower the panel into the hinged position. Torsion springs on the hinging side of the panel should also be in the lowered position to ensure that the Weave panel does not come into contact with adjacent panels when hinging.

Repeat operation on opposite side if panel needs to be removed from the ceiling. Ensure that panels are stored in accordance with storage guidance in this guide.

Waste Disposal Management

Weave Radiant Textile Panels are shipped and packaged with protective material that should be disposed of in an appropriate manner.

Please remove or recycle waste and packaging materials per your local requirements.

The information contained in this document only provides guidance for the installation of Lindner PARC products. All Lindner PARC products should only be installed by trained professionals and installation responsibility remains with the installer. Lindner PARC reserves the right to review, alter, amend or remove published data without notice as our policy is one of constant improvement. The information contained in this installation guide is believed to be correct at the date of publication. Whilst Lindner PARC will endeavor to keep its publications up to date, readers will appreciate that between publications there will be changes in laws or other developments affecting the accuracy of the information contained in this installation guide.



Product Improvement is a continuing endeavour at Lindner PARC. Therefore, specifications are subject to change without notice. Consult your sales representative for current specifications or more detailed information.
Not all products may be available in all geographic areas. 2024, v005