

CORE

Product Overview – Metric



Table of Contents

Product Overview

General	3
Before You Start.....	3

Installation Instructions

Required Tools and Equipment.....	4
Site Conditions, Storage and Handling	5
Installation of Core.....	7

General

WARNING! Read this and save these instructions before beginning to install Core components









To reduce the risk of fire, electric, shock, or injury to persons, observe the following:

- A. When cutting or drilling into wall or ceiling, do not damage electrical wiring and other hidden utilities.
- B. Use this unit only in the manner intended by the manufacturer. If you have any questions, contact the manufacturer or Lindner PARC Technical Support.
- C. Ensure suspension rods are rated by structural engineer, if using components other than the ones specified in this document.

Before You Start

Inspect all product parts for flaws and shipping damage. If anything is discovered to be damaged, contact the shipping company and manufacturer immediately.

Tools Required

 <p>2m level (Optional)</p>	 <p>Laser level</p>	 <p>Measuring tape</p>	 <p>10mm Wrench or Socket</p>
 <p>13mm Wrench or Socket</p>	 <p>5mm Allen Key</p>	 <p>Cordless Drill</p>	 <p>Hammer Drill (Optional)</p>

Site Conditions, Storage and Handling

- Read the Installation Guide before handling
- Reference the tags and labels associated with each part (as required).

Consideration should be given to the advice of the Occupational Health & Safety Representative regarding manual handling. An assessment should be made of any risk and if necessary mechanical lifting equipment should be used.

Components

The following components are orderable through Lindner PARC. Components referenced in this document that are not in this list are recommendations and to be supplied by others.

Figure 1 – Core with Weave Panels, ISO View

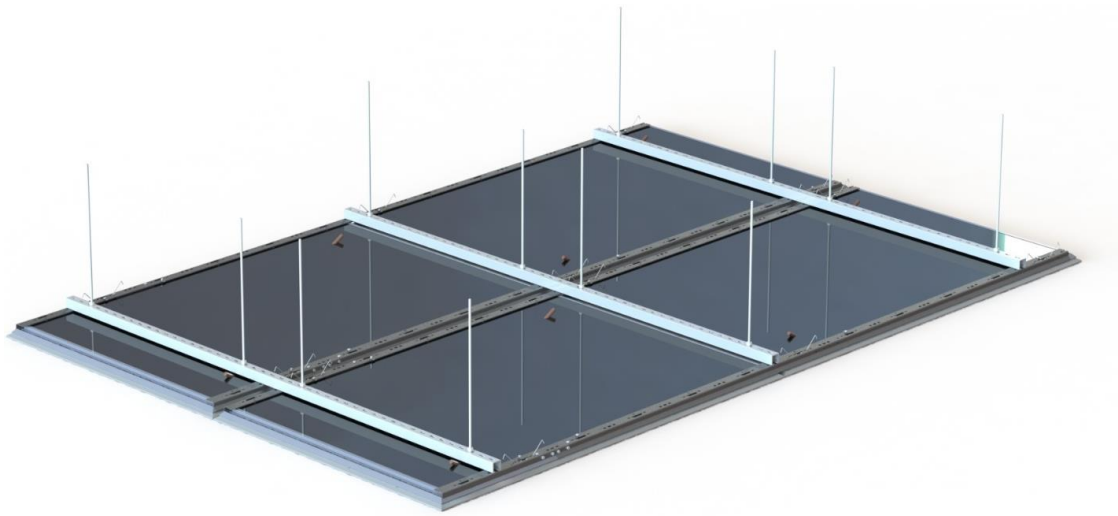
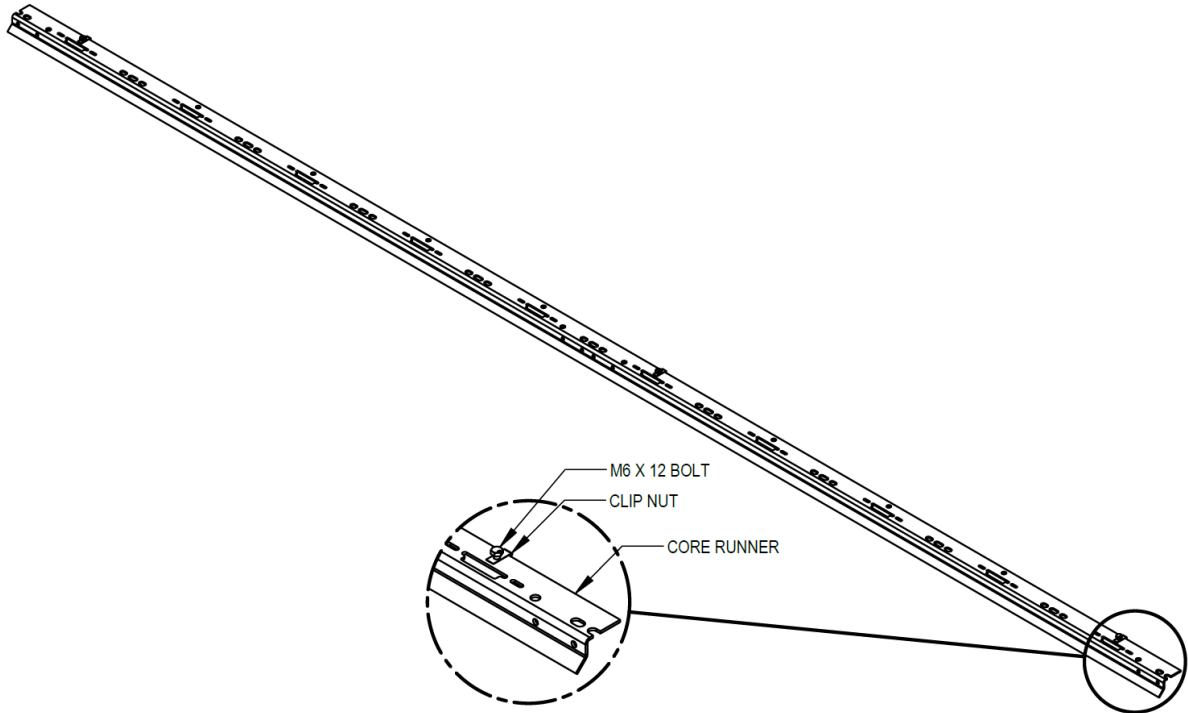

Figure 2 – Core Only, ISO View



Runner

Figure 3 – Core Runner



Splice Plate

Figure 4 – Splice Plate

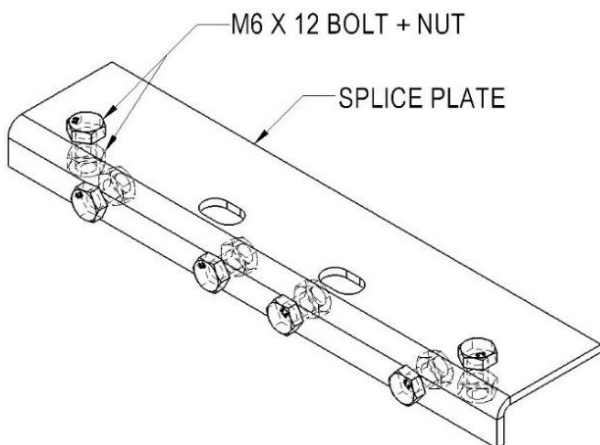

Node C-Bracket

Figure 5 – Node C-Bracket

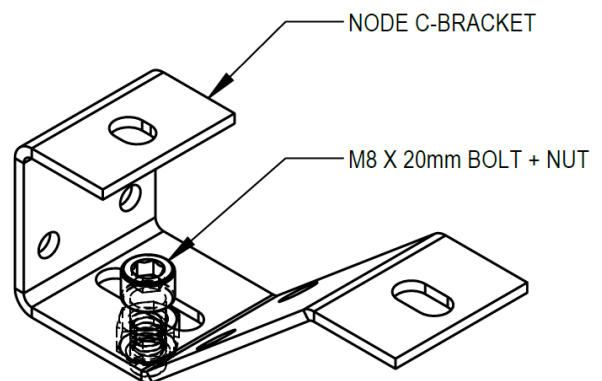

Installation of Core

The Core system consists of 4 layers: The suspension rods, strut channels, Core components, and the panels.

Layers 1 and 2 are to be supplied and coordinated by others.

Step 1 – Layer 1 – Suspension Rods

The connection between the strut channels and deck is recommended to be with threaded rod. Installation from the deck to Core is the responsibility of the installer. Refer to layout drawing provided by Lindner PARC for project specific strut locations when setting out locations of threaded rod or alternatives in the ceiling.

The threaded rods can be substituted with alternative mounting solutions. It is the responsibility of the installer to ensure proper load ratings have been calculated and approved by an engineer for any solution. Please refer to product submittals for weights of Core components and the associated panels or Node channels being installed.

Step 1a – Positioning in Y-Direction

Locate your first line by referencing the location of the first panel. The first line is to be located within 500mm of the panel edge and not within a space 100-275mm from the edge of the panel as shown in Figure 7 below.

Subsequent rows shall be patterned in increments of 300mm, with a max of 1500mm between two rows as shown in Figure 8 below.

Figure 6 – Exploded view of Core System Layers

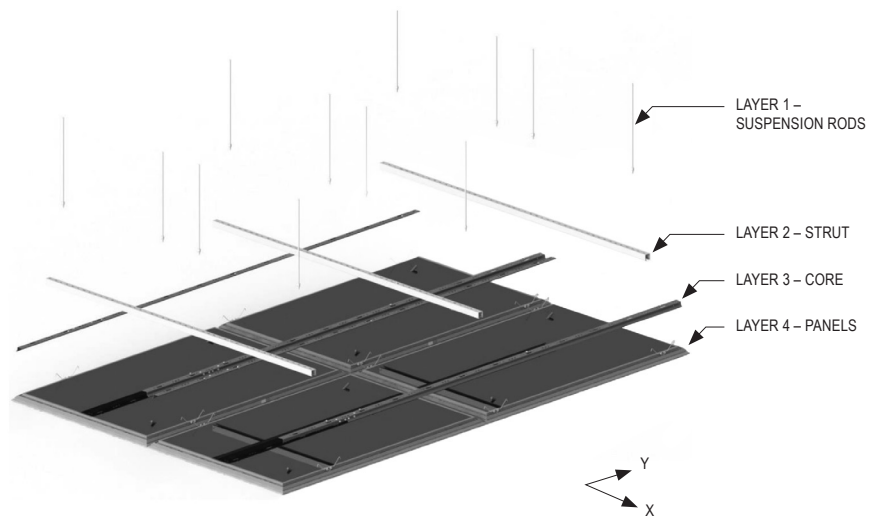
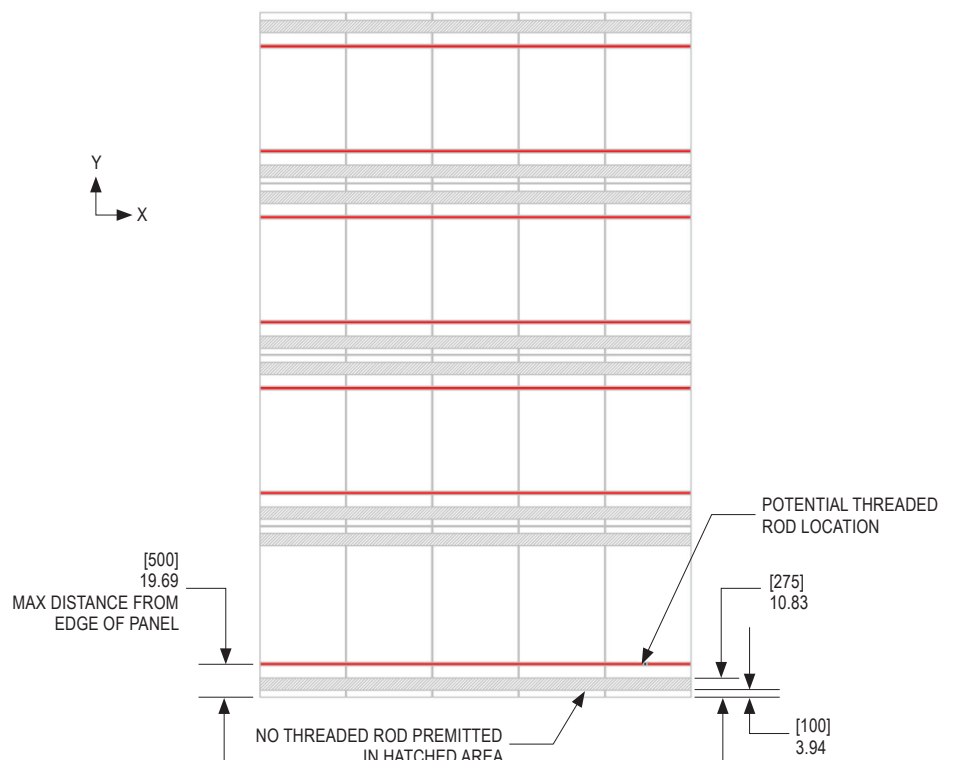

Figure 7 – Top view showing positions of threaded rod in Y-direction – 1st row



Step 1b – Positioning in X-Direction

Locate your first line by referencing the location of the first panel. The first line is to be located within 500mm of the panel edge.

Subsequent rows shall be patterned based on the strut channel used, with a maximum distance of 1500mm.

Step 1c – Installation

It is the responsibility of the installer to supply required hardware and install layer 1 per local building codes.

Step 2 – Layer 2 – Strut

It is the responsibility of the installer to ensure appropriate strut channels are sources for the project that are rated to handle the load of the ceiling.

Step 2a – Positioning in Y Direction

Refer to “Step 1a – Positioning in Y Direction”

IMPORTANT: When installing Weave, consideration must be given to locations of the strut channel as there could be interference with the radiant tubing inlet or outlet. The configuration of inlet and outlet may vary and there can be instances where the strut channel can exist in the restricted zone. Please review inlet and outlet locations on a per project basis if strut channel is desired to be placed in a restricted zone.

Figure 8 – Top view showing positions of threaded rod in Y-direction – 2nd row

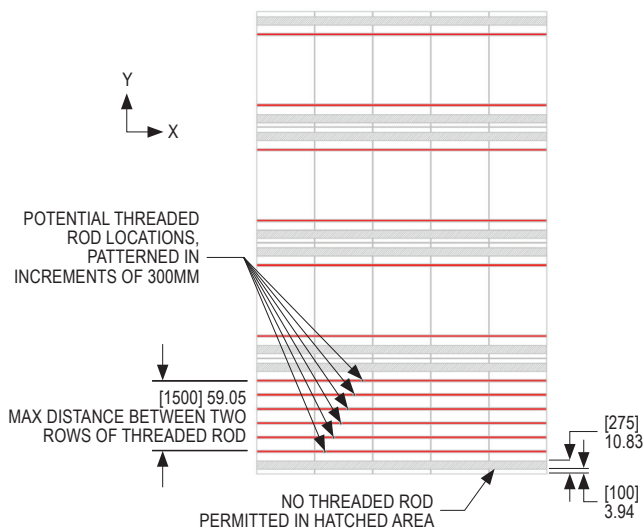
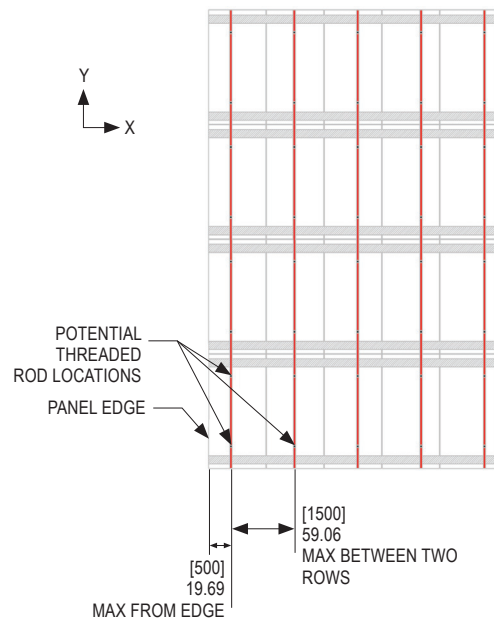

Figure 9 – Positioning threaded rod in X-direction



Step 2b – Positioning in X Direction

Use adjacent walls to position the strut channels, refer to project documentation on specified locations of panels.

Strut channel is recommended to be located 25mm inward of the edge of the panel to avoid potential interference with optional end caps.

Step 2c – Installation

It is the responsibility of the installer to supply the required hardware and install layer 2 in the correct position per local building codes.

It is not permitted to have threaded rod or other suspension components extend past the bottom of the strut channel.

Figure 10 – Positioning strut in X-direction

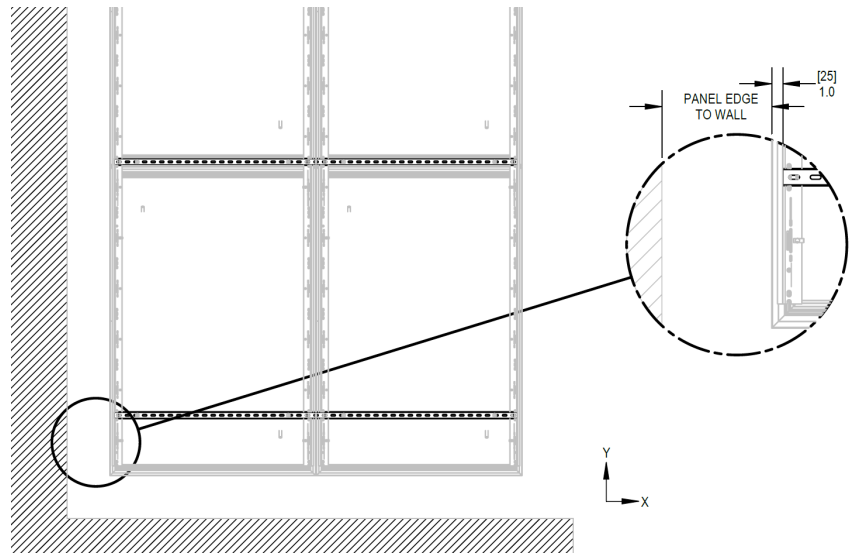

Figure 11 – Threaded rod depth restraint

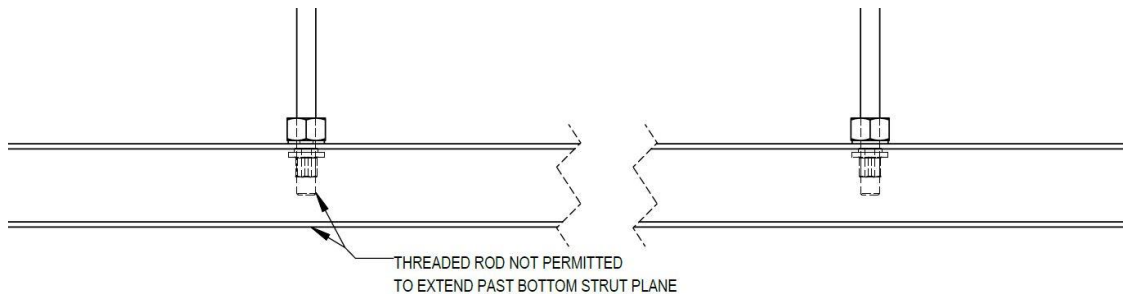
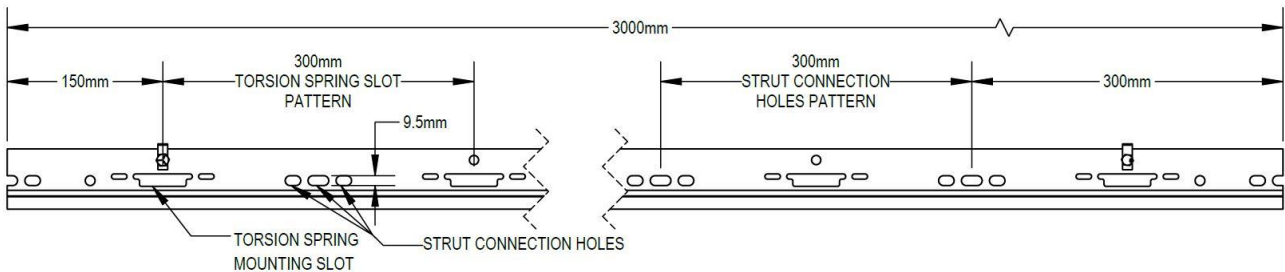

Figure 12 – Runner dimensions



Step 3a – Positioning Runners in Y-Direction

When positioning the first runner in a series, the leading edge is recommended to be inset of the edge of the Weave panel by 50mm with a maximum distance of 250mm from the torsion spring slot to the panel edge. Ensure the runner does not extend past the end of the Weave panel for panels on the edge of an array.

Step 3b – Positioning Runners in X-Direction

The indicated edge on the runner will be used for all runner positioning.

Set the position of the first Core runner by taking the panel edge to wall measurement, adding 72.5mm, and marking that position on your strut channel. Align the measurement edge of the runner to the mark on your strut.

Figure 13 – Positioning runners in Y-direction

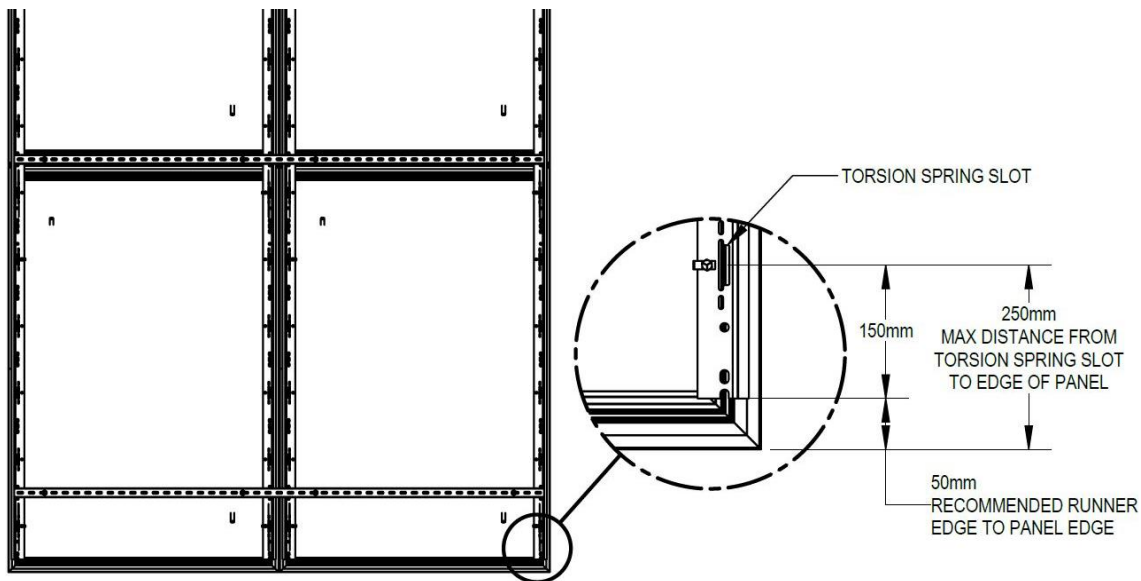

Figure 14 – Runner reference edge

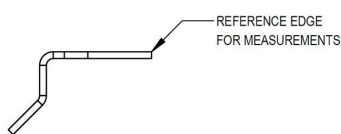
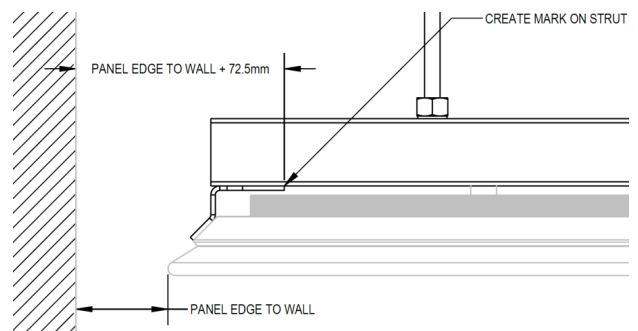

Figure 15 – Runner positioning in X-direction – 1st row



To position the second runner for the Weave panel, subtract 145mm from the width of the panel to give you the distance between the two respective runner measurement edges as shown in figure 16 below.

To position the runner for the adjacent panel, add 145mm to the panel gap and set your runner at that location. Note that different offsets are required when a Node channel is adjacent to the panel, covered in the next section.

Repeat steps above for as many panels are required in the x-direction.

Step 3c – Positioning Runners for Adjacent Panels in Node Systems

In systems with Node Flush or Recessed channels, the strut channel goes over top of Node to maintain a continuous installation.

When installing Node Channels adjacent to Core Runners, it is recommended to have the Node channels on site to easily set the distance between runners on adjacent panels. Where the Node channels aren't available, follow the spacing set out in Figures 19, 20, and 21 below.

Figure 16 – Runner positioning in X-direction - 2nd row

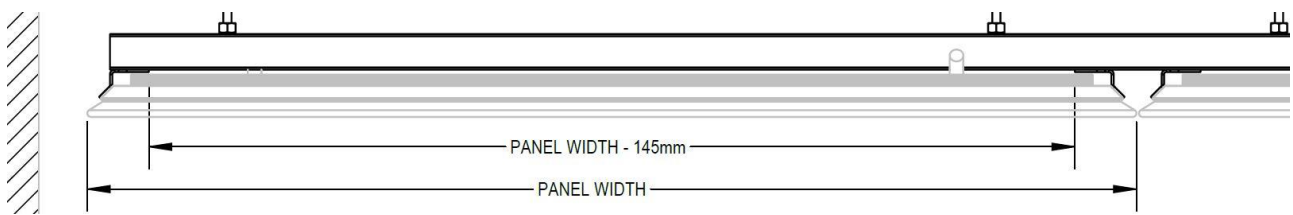

Figure 17 – Runner panel gap

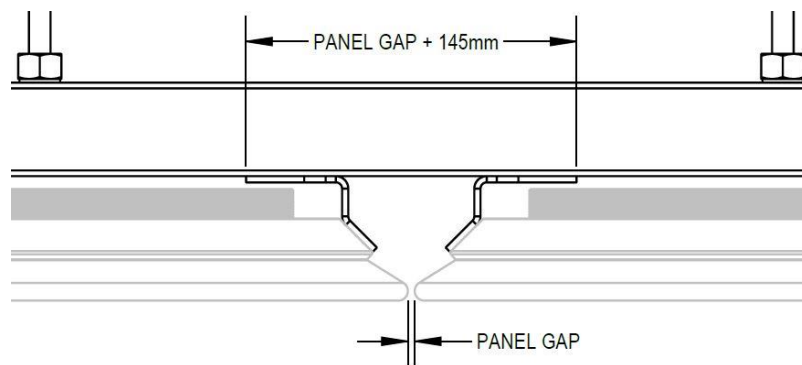
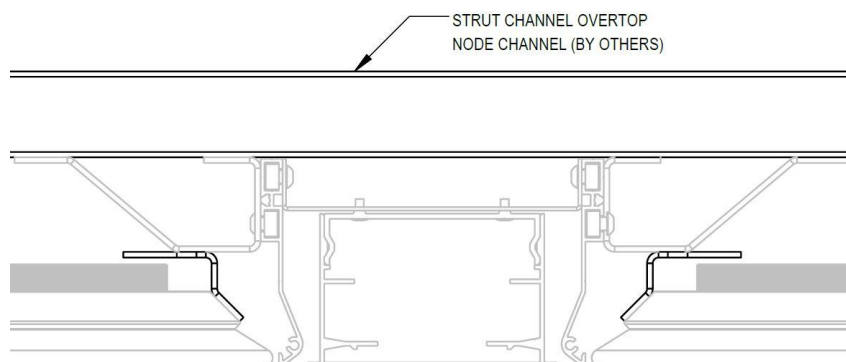

Figure 18 – Core with Node



Repeat the listed steps above for as many rows of Weave panels as you have in your array. If the Node channels aren't available at the time of Core installation, it may be required to loosen a runner prior to installing the Node channel to fit the channel through the opening between two adjacent runners.

Positioning Core Node Connection Bracket

The Core Node connection bracket position will be different between Node flush channel, Node flush channel with diffuser, and Node recessed channel. The gap between the channel and the panel is also controlled by the position of the node connection bracket.

Node Flush Channel

Figure 19 – Node flush channel offsets

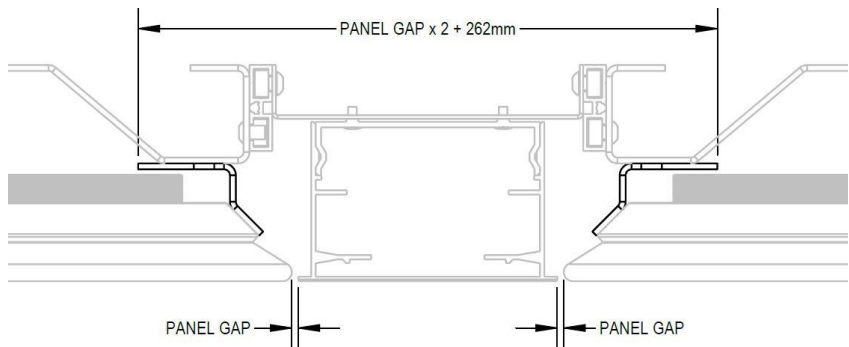

Node Flush Channel with Diffuser

Figure 20 – Node flush channel with diffuser offsets

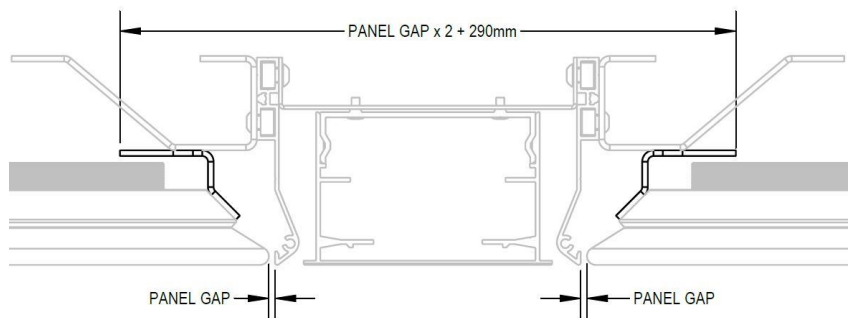

Node Recessed Channel with Diffuser

Figure 21 – Node recessed channel offsets

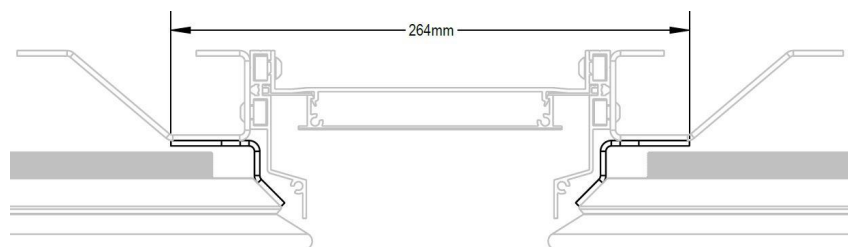
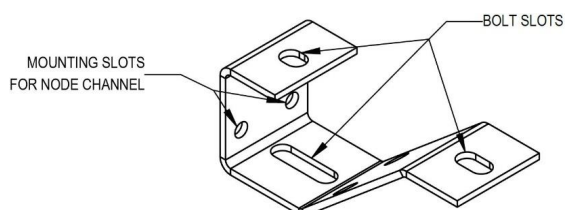

Figure 22 – Node connection bracket mounting and bolt slots



Step 3d – Installation of Core Runner Splice Bracket

Runners can be spliced together to span the required length of the ceiling array with the Core Splice Runner bracket. Installation of the bracket is shown in figures 23, 24, and 25 below.

Step 3e – Installation of Runners to Strut

The runners are designed to be installed to the strut through the indicated holes, which are repeated along the runner every 300mm. Hardware to be provided by installers.

Figure 23 – Exploded view of Core Runner and Splice Plate

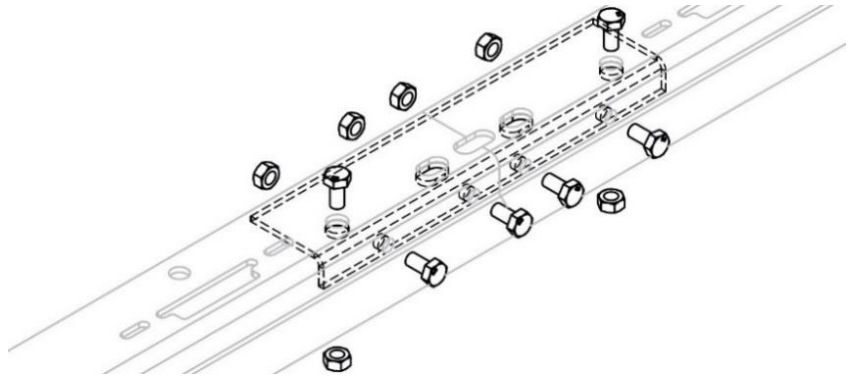

Figure 24 – Iso view of Core Runner and Splice Plate

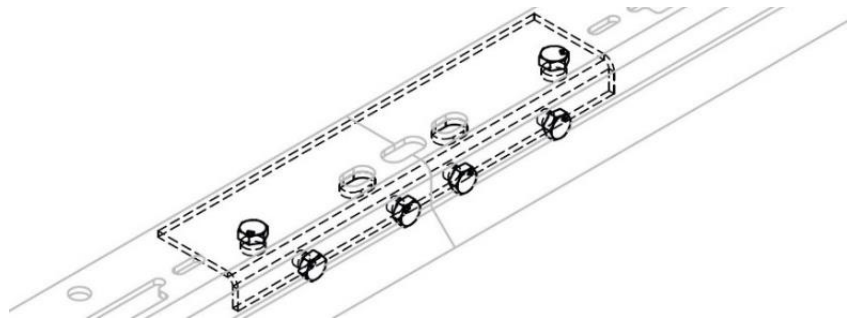

Figure 25 – Side View of Core Runner and Splice Plate

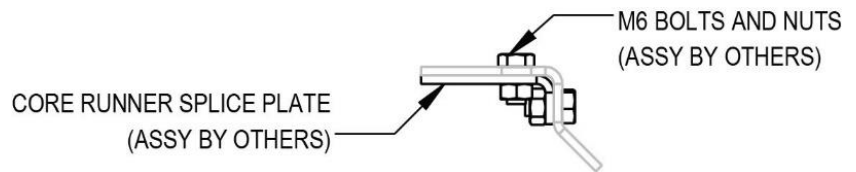

Figure 26 – Runner Strut hole spacing

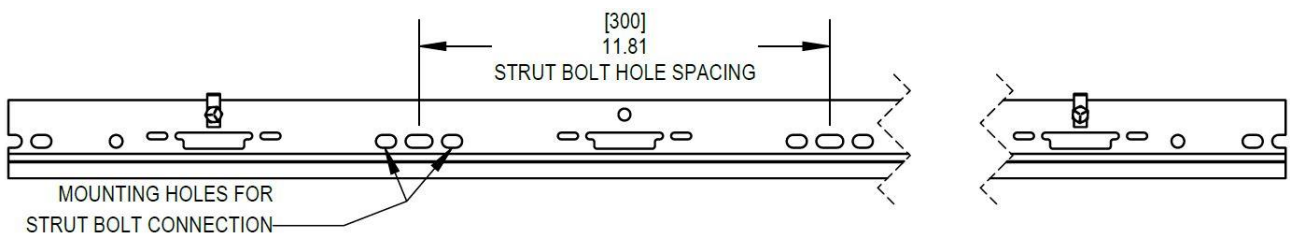

Figure 27 – Installation of runner to strut - Front view

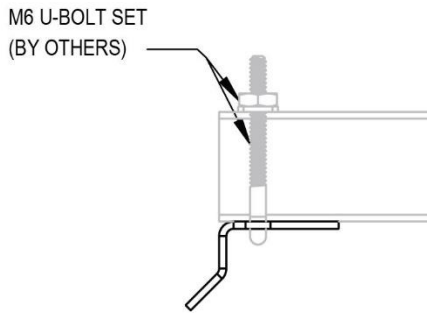
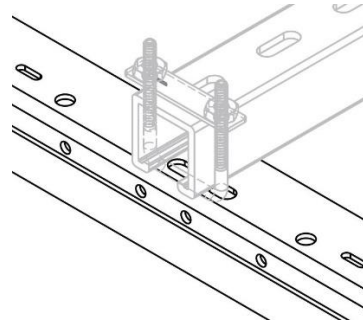

Figure 28 – Installation of runner to strut - Iso view



Step 3f – Installation of Runners to Strut for Node Systems

It is the responsibility of the installer to provide the appropriate nut and bolt to attach to the strut channel. The M8 x 20mm bolt + nut, and Core Node Connection bracket are provided by Lindner PARC.

It is recommended to install the nut and bolt, Node connection bracket, and channel nut onto the runner and then install that assembly into the Strut channel that is suspended in the ceiling.

Step 6 – Install Panels and/or Node Channels

Please refer to product installation guides for information on how each product is installed into the Core Mounting System.

Cutting Runners to Length on Site

Runners can be cut to length as required. If the runner to be cut is the last in a series and does not require a splicing plate attachment, it can be cut at any position on the runner.

For situations where the runner is required to be cut and the splice plate will be used, the cut must be centered in between any 2 torsion spring slots as shown in figure 30 below.

Figure 29 – Installation of Runners to Strut for Node Systems

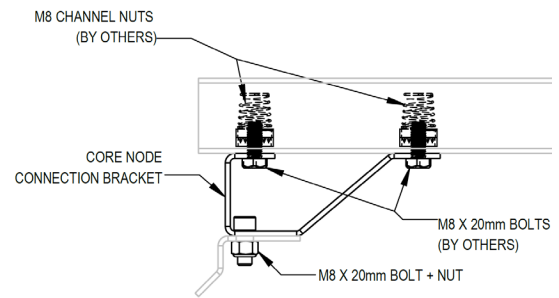
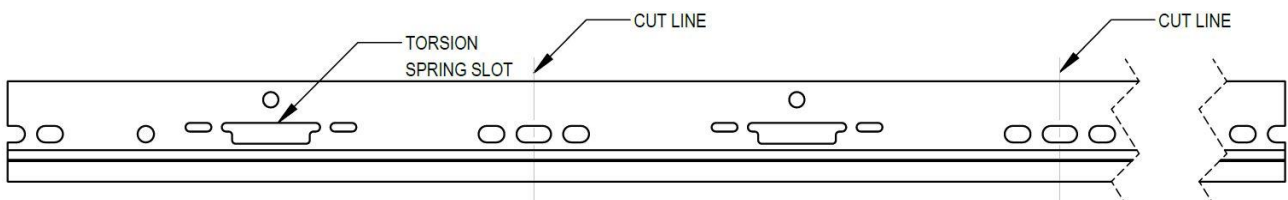
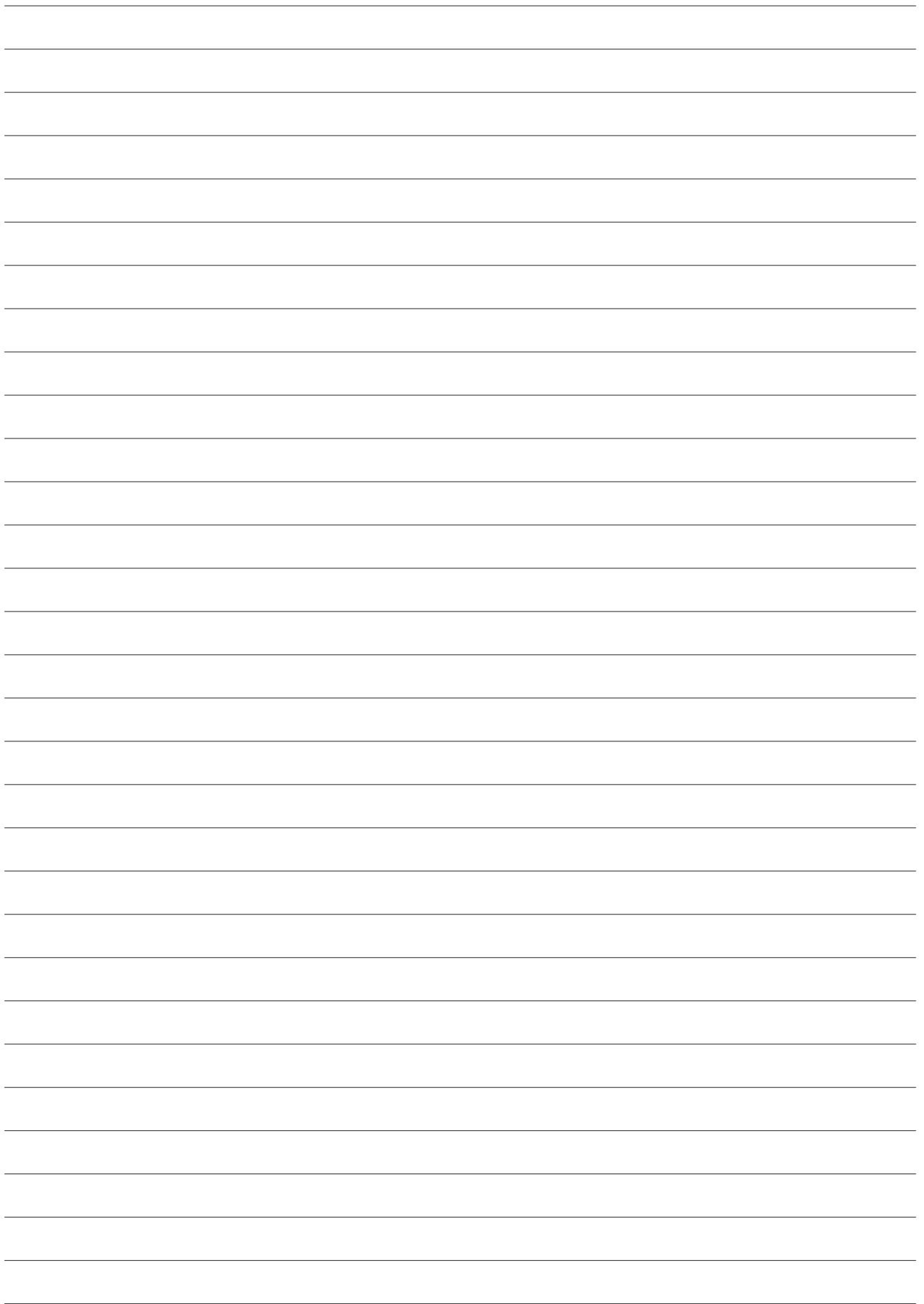

Figure 30 – Runner cut line for onsite cutting



This ensures proper patterning of torsion springs is maintained. Holes may be required to be drilled on the runner to correspond with the holes on the splice plate.





www.parc-ceilings.com

Product Improvement is a continuing endeavour at Lindner PARC. Therefore, specifications are subject to change without notice. Consult your sales representative for current specifications or more detailed information.

Not all products may be available in all geographic areas. 2024 v002