

# SUBMITTAL

## GENERAL CONSTRUCTION - NODE SPRINKLER

### PROJECT CHECKLIST

TAG: \_\_\_\_\_

QUANTITY: \_\_\_\_\_

### SPRINKLER STYLE:

CONCEALED PENDANT

FLUSH PENDANT

### CONFIGURATION:

RAPIDROP RD102

RAPIDROP RD105

RAPIDROP RD107

### MOUNTING:

FLUSH CHANNEL

TRIMLESS

### DEVICE FACE FINISH:

BLACK POLYMER - B17

WHITE POLYMER - RAL 9006

BLACK - PRICE B17

WHITE - RAL 9016

ANODIZED - CLEAR SATIN

ANODIZED - CHAMPAGNE SATIN

ANODIZED - LIGHT BRONZE SATIN

ANODIZED - MEDIUM BRONZE SATIN

ANODIZED - DARK BRONZE SATIN

ANODIZED - BLACK SATIN

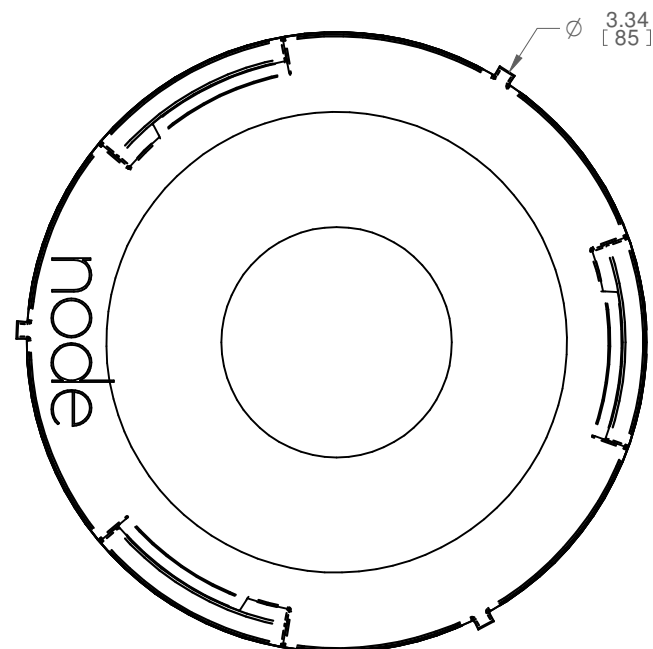

TOP VIEW

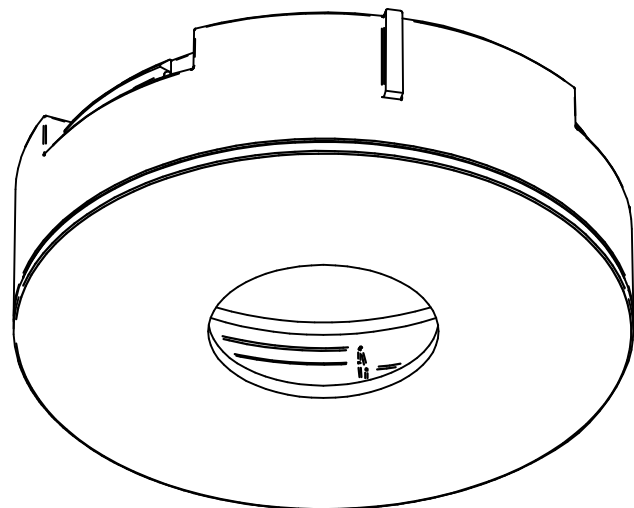

ISOMETRIC VIEW

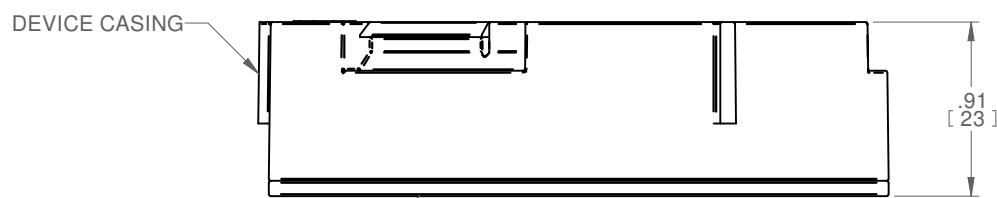

SIDE VIEW

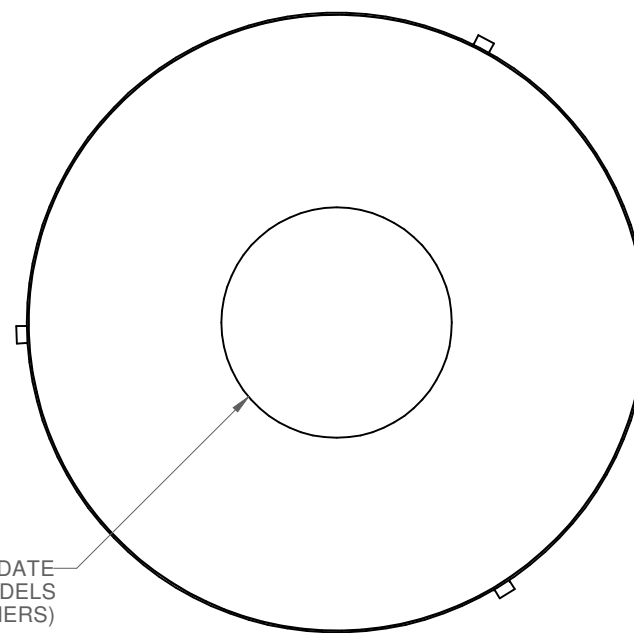

BOTTOM VIEW

CUTOUT TO ACCOMMODATE SPECIFIED SPRINKLER MODELS (SPRINKLERS BY OTHERS)



### CONSTRUCTION:

- DEVICE CASING
  - o MOULDED POLYMER
- OUTER HOUSINGS
  - o MOULDED POLYMER

### FINISH:

- ALL HARDWARE: MILL FINISH UNLESS OTHERWISE SPECIFIED

### MECHANICAL SERVICE

- BY OTHERS

### CONTROLS

- BY OTHERS

### ASSEMBLY AND INSTALLATION

- ALL COMPONENTS SHOWN ARE FACTORY ASSEMBLED BY PARC UNLESS OTHERWISE NOTED
- ALL INSTALLATION BY OTHERS AND METHODS SHOWN ARE NOTIONAL
- (ASSY BY OTHERS): PROVIDED BY PARC, FIELD ASSEMBLED BY OTHERS
- (BY OTHERS): PROVIDED AND FIELD ASSEMBLED BY OTHERS

### NOTES:

- DIMENSIONS SHOWN IN PARENTHESES ARE FOR REFERENCE ONLY (X.XX)
- METRIC DIMENSIONS SHOWN IN BRACKETS [X.XX]
- PRODUCT FINISH MAY VARY IN TONE, GLOSS AND TEXTURE; VARIATIONS ARE WITHIN PARC QUALITY STANDARDS
- TBC: DETAILS TO BE CONFIRMED

REV	DATE	DRAWN BY	CHECKED BY
C	2021-06-10	NPT	KVR
B	2021-06-01	NPT	KVR
A	2020-06-16	NPT	SMB

ALL DIMENSIONS IN INCHES UNLESS OTHERWISE SPECIFIED

TOLERANCES UNLESS OTHERWISE SPECIFIED				
LINEAR	X.X ± .06	X.XX ± .03	X.XXX ± .01	INCHES
ANGULAR	X ± 1	X.X ± .5	X.XX ± .25	DEGREES

PROJECT

DRAWING TITLE  
**NODE SPRINKLER SUBMITTAL**

SUBMITTAL NUMBER	<b>272422</b>	SHEET 1 OF 4	SIZE B
------------------	---------------	--------------	--------

© COPYRIGHT LINDNER CANADA 2024

**GENERAL CONSTRUCTION - CHANNEL MOUNTED**

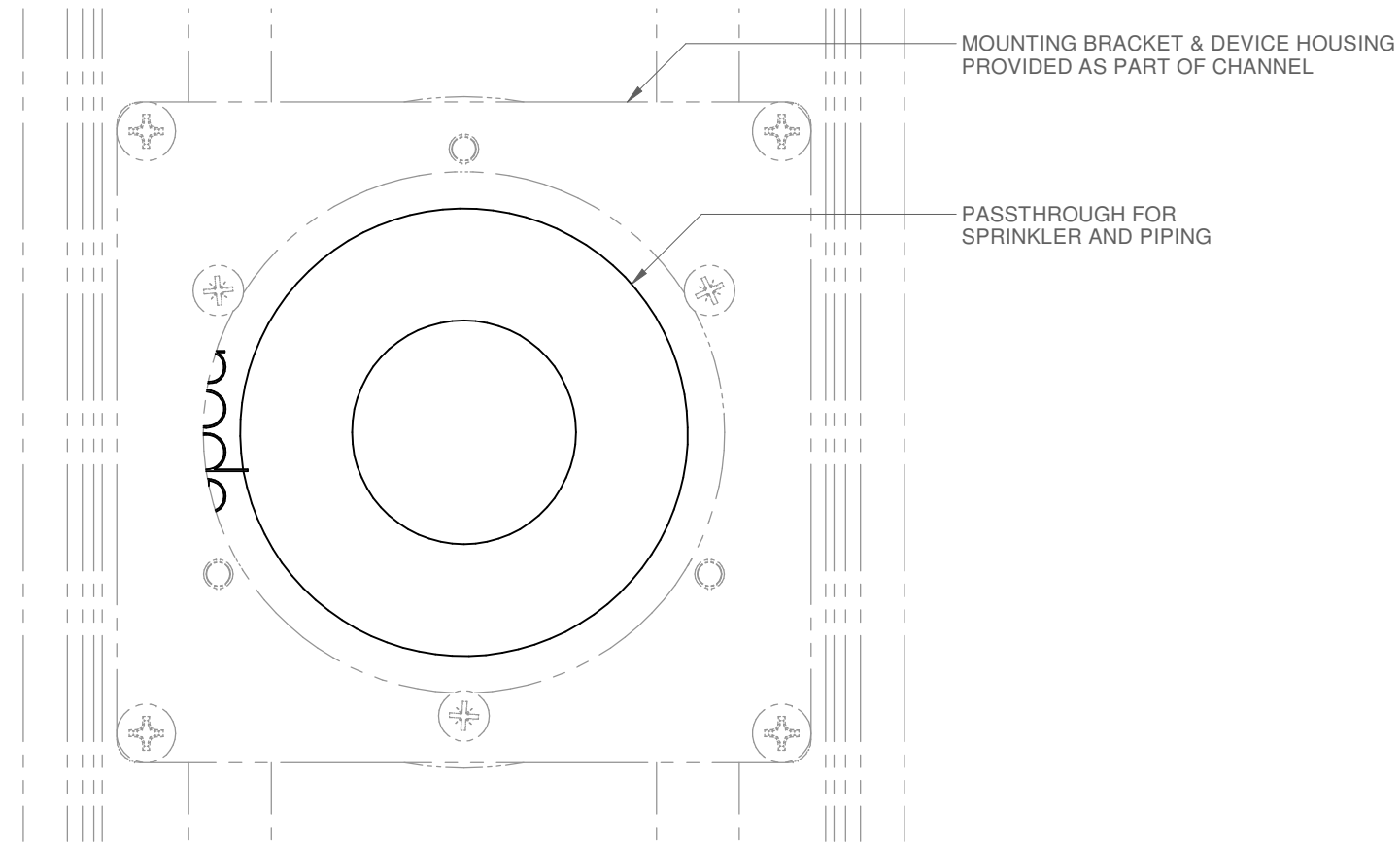

**FLUSH CHANNEL TOP VIEW**

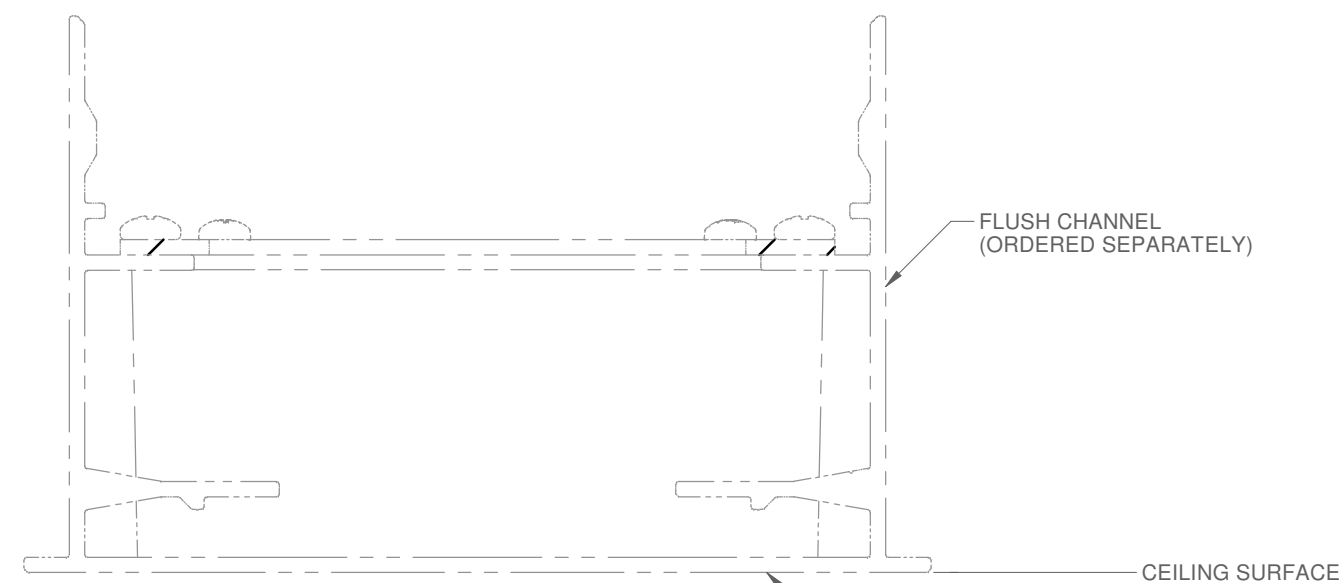

**FLUSH CHANNEL END VIEW**

**CONSTRUCTION:**

- DEVICE CASING
  - o MOULDED POLYMER
- OUTER HOUSINGS
  - o MOULDED POLYMER

**FINISH:**

- ALL HARDWARE: MILL FINISH UNLESS OTHERWISE SPECIFIED

**MECHANICAL SERVICE**

- BY OTHERS

**CONTROLS**

- BY OTHERS

**ASSEMBLY AND INSTALLATION**

- ALL COMPONENTS SHOWN ARE FACTORY ASSEMBLED BY PARC UNLESS OTHERWISE NOTED
- ALL INSTALLATION BY OTHERS AND METHODS SHOWN ARE NOTIONAL
- (ASSY BY OTHERS): PROVIDED BY PARC, FIELD ASSEMBLED BY OTHERS
- (BY OTHERS): PROVIDED AND FIELD ASSEMBLED BY OTHERS

**NOTES:**

- DIMENSIONS SHOWN IN PARENTHESES ARE FOR REFERENCE ONLY (X.XX)
- METRIC DIMENSIONS SHOWN IN BRACKETS [X.XX]
- PRODUCT FINISH MAY VARY IN TONE, GLOSS AND TEXTURE; VARIATIONS ARE WITHIN PARC QUALITY STANDARDS
- TBC: DETAILS TO BE CONFIRMED

REV	DATE	DRAWN BY	CHECKED BY
C	2021-06-10	NPT	KVR
B	2021-06-01	NPT	KVR
A	2020-06-16	NPT	SMB

ALL DIMENSIONS IN INCHES UNLESS OTHERWISE SPECIFIED

TOLERANCES UNLESS OTHERWISE SPECIFIED				
LINEAR	X.X ± .06	X.XX ± .03	X.XXX ± .01	INCHES
ANGULAR	X ± 1	X.X ± .5	X.XX ± .25	DEGREES

PROJECT

DRAWING TITLE  
**NODE SPRINKLER SUBMITTAL**

SUBMITTAL NUMBER	<b>272422</b>	SHEET 2 OF 4	SIZE <b>B</b>
------------------	---------------	--------------	---------------

**GENERAL CONSTRUCTION - TRIMLESS**

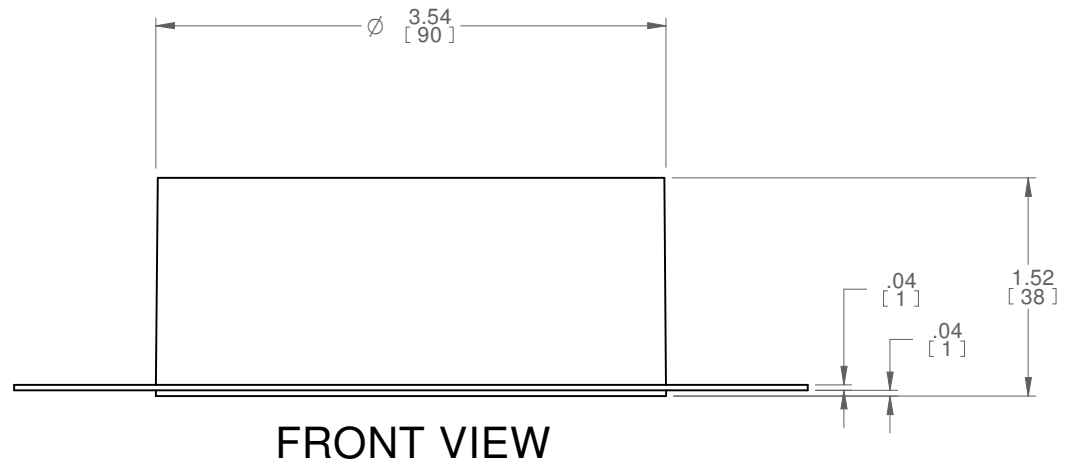

TRIMLESS HOUSING

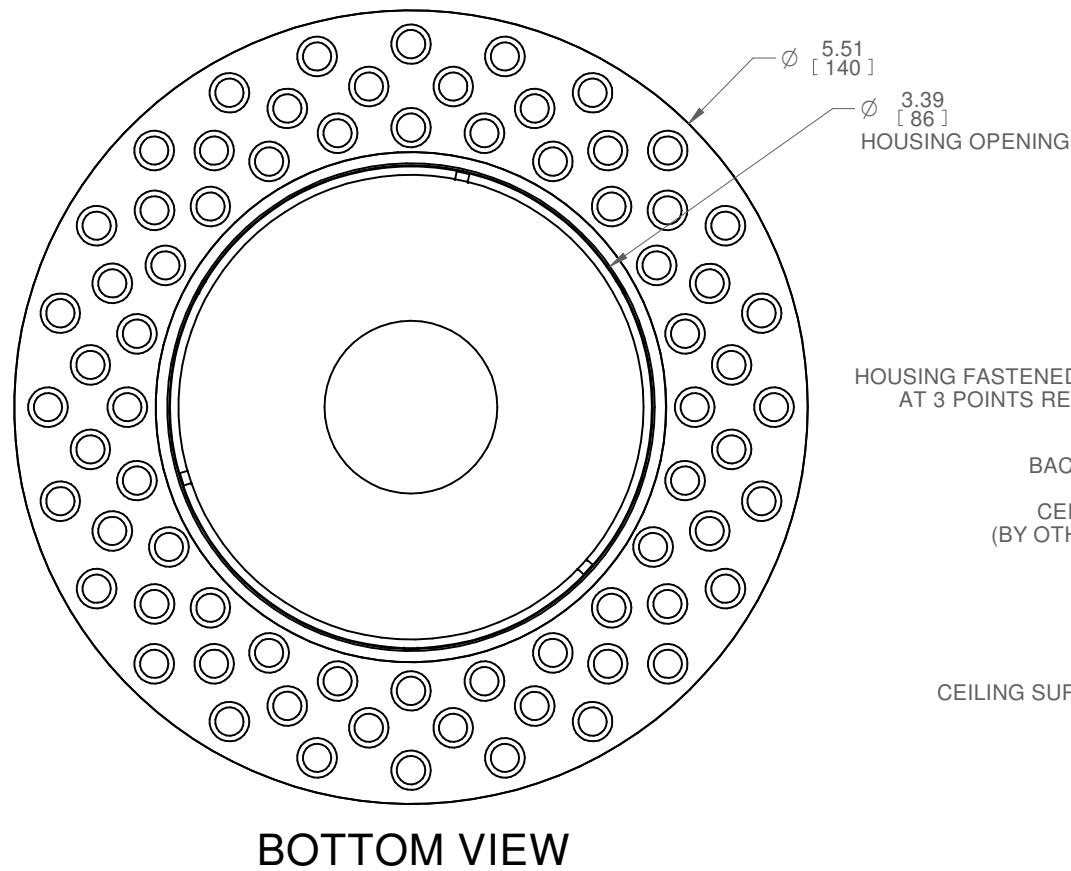
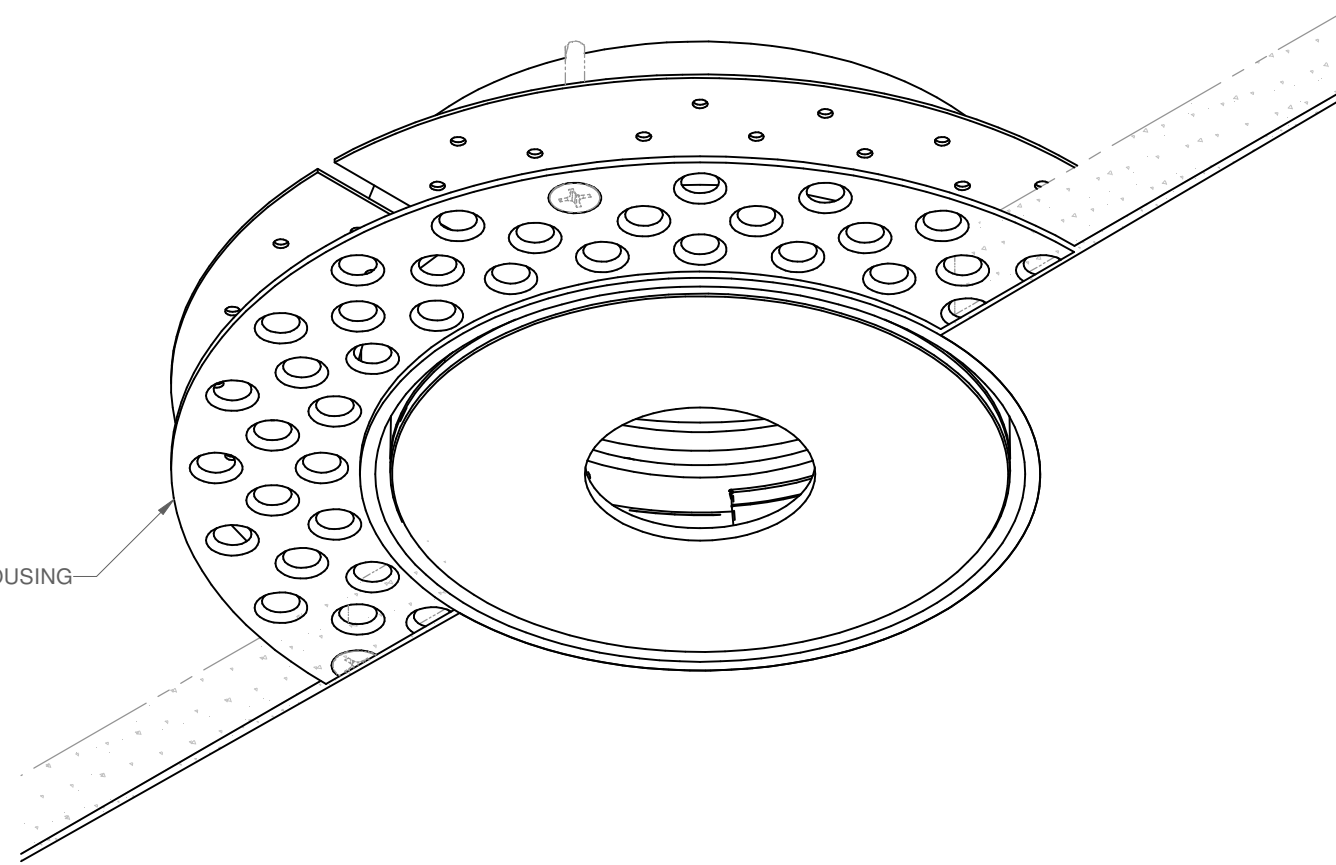

HOUSING FASTENED TO CEILING  
AT 3 POINTS RECOMMENDED  
(BY OTHERS)

BACKING RING  
CEILING  
(BY OTHERS)

CEILING SURFACE

PLASTER  
(BY OTHERS)

(.08 [2])  
DEVICE FACE TO  
UNFINISHED CEILING SURFACE

Ø ( 3.75 [95] )  
RECOMMENDED CUTOUT

CEILING CROSS SECTION

**CONSTRUCTION:**

- DEVICE CASING
  - o MOULDED POLYMER
- OUTER HOUSINGS
  - o MOULDED POLYMER

**FINISH:**

- ALL HARDWARE: MILL FINISH UNLESS OTHERWISE SPECIFIED

**MECHANICAL SERVICE**

- BY OTHERS

**CONTROLS**

- BY OTHERS

**ASSEMBLY AND INSTALLATION**

- ALL COMPONENTS SHOWN ARE FACTORY ASSEMBLED BY PARC UNLESS OTHERWISE NOTED
- ALL INSTALLATION BY OTHERS AND METHODS SHOWN ARE NOTIONAL
- (ASSY BY OTHERS): PROVIDED BY PARC, FIELD ASSEMBLED BY OTHERS
- (BY OTHERS): PROVIDED AND FIELD ASSEMBLED BY OTHERS

**NOTES:**

- DIMENSIONS SHOWN IN PARENTHESES ARE FOR REFERENCE ONLY (X.XX)
- METRIC DIMENSIONS SHOWN IN BRACKETS [X.XX]
- PRODUCT FINISH MAY VARY IN TONE, GLOSS AND TEXTURE; VARIATIONS ARE WITHIN PARC QUALITY STANDARDS
- TBC: DETAILS TO BE CONFIRMED

REV	DATE	DRAWN BY	CHECKED BY
C	2021-06-10	NPT	KVR
B	2021-06-01	NPT	KVR
A	2020-06-16	NPT	SMB

ALL DIMENSIONS IN INCHES UNLESS OTHERWISE SPECIFIED

TOLERANCES UNLESS OTHERWISE SPECIFIED			
LINEAR	X.X ± .06	X.XX ± .03	X.XXX ± .01
ANGULAR	X ± 1	X.X ± .5	X.XX ± .25

PROJECT

DRAWING TITLE  
**NODE SPRINKLER SUBMITTAL**

SUBMITTAL NUMBER	<b>272422</b>	SHEET 3 OF 4	SIZE B
------------------	---------------	--------------	--------

GENERAL CONSTRUCTION - SPRINKLER INTEGRATION

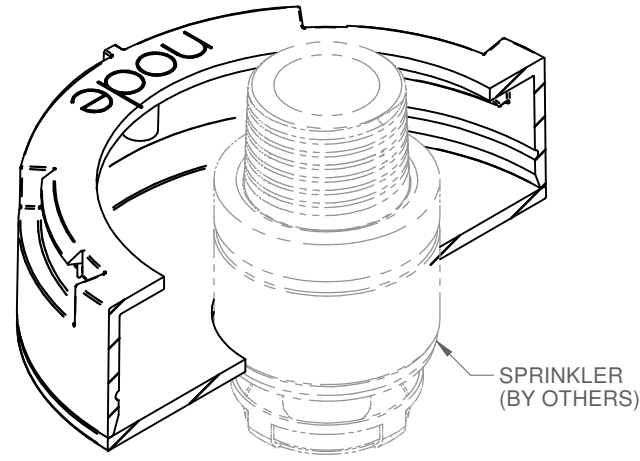

ISOMETRIC VIEW  
RAPIDROP RD102

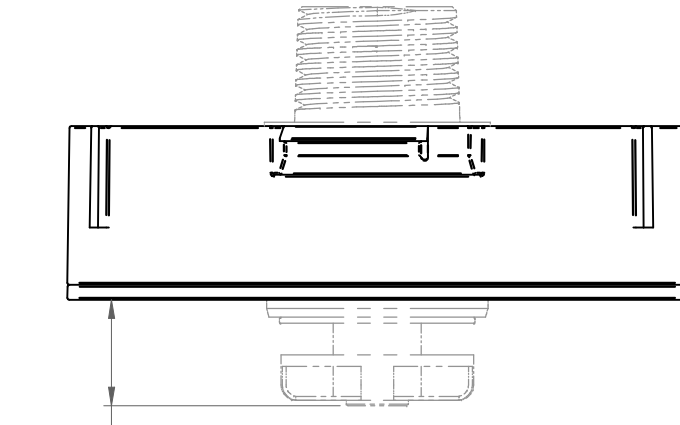

SIDE VIEW  
RAPIDROP RD102

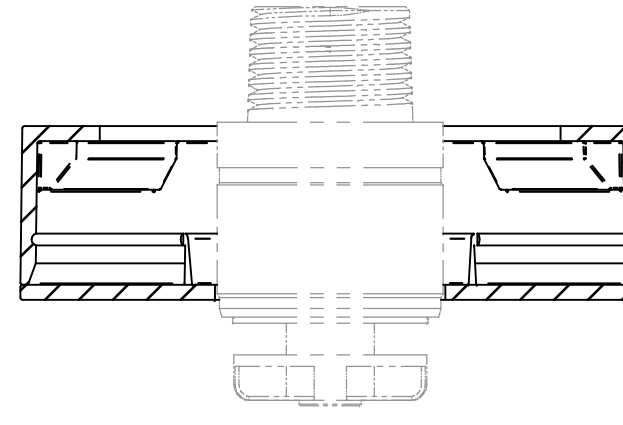

SECTION VIEW  
RAPIDROP RD102

**CONSTRUCTION:**

- DEVICE CASING
  - o MOULDED POLYMER
- OUTER HOUSINGS
  - o MOULDED POLYMER

**FINISH:**

- ALL HARDWARE: MILL FINISH UNLESS OTHERWISE SPECIFIED

**MECHANICAL SERVICE**

- BY OTHERS

**CONTROLS**

- BY OTHERS

**ASSEMBLY AND INSTALLATION**

- ALL COMPONENTS SHOWN ARE FACTORY ASSEMBLED BY PARC UNLESS OTHERWISE NOTED
- ALL INSTALLATION BY OTHERS AND METHODS SHOWN ARE NOTIONAL
- (ASSY BY OTHERS): PROVIDED BY PARC, FIELD ASSEMBLED BY OTHERS
- (BY OTHERS): PROVIDED AND FIELD ASSEMBLED BY OTHERS

**NOTES:**

- DIMENSIONS SHOWN IN PARENTHESES ARE FOR REFERENCE ONLY (X.XX)
- METRIC DIMENSIONS SHOWN IN BRACKETS [X.XX]
- PRODUCT FINISH MAY VARY IN TONE, GLOSS AND TEXTURE; VARIATIONS ARE WITHIN PARC QUALITY STANDARDS
- TBC: DETAILS TO BE CONFIRMED

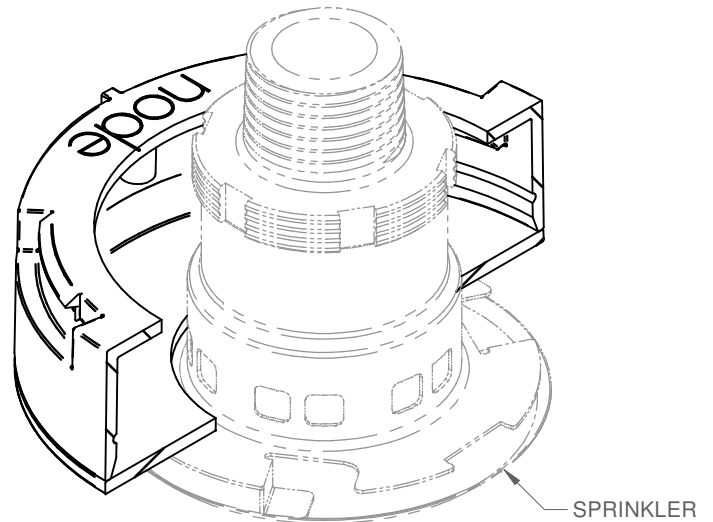

ISOMETRIC VIEW  
RAPIDROP RD105 & RD107

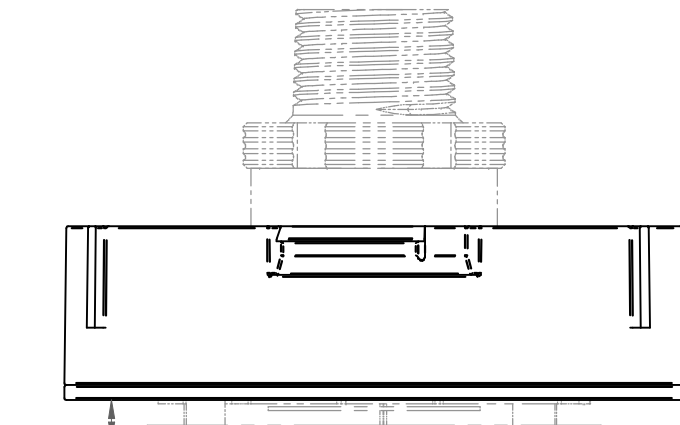

SIDE VIEW  
RAPIDROP RD105 & RD107

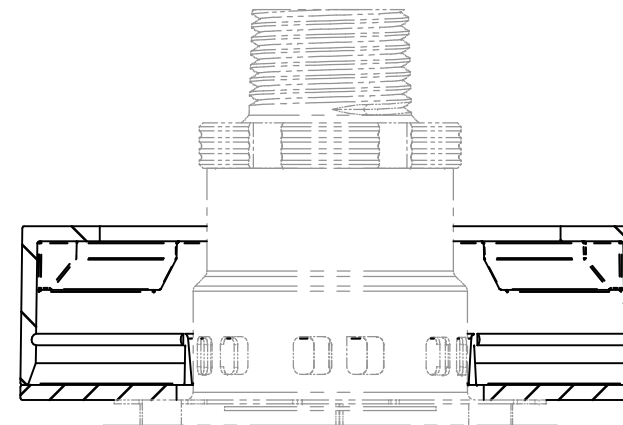

SECTION VIEW  
RAPIDROP RD105 & RD107

REV	DATE	DRAWN BY	CHECKED BY
C	2021-06-10	NPT	KVR
B	2021-06-01	NPT	KVR
A	2020-06-16	NPT	SMB

ALL DIMENSIONS IN INCHES UNLESS OTHERWISE SPECIFIED

TOLERANCES UNLESS OTHERWISE SPECIFIED			
LINEAR	X.X ± .06	X.XX ± .03	X.XXX ± .01
ANGULAR	X ± 1	X.X ± .5	X.XX ± .25
			INCHES
			DEGREES

PROJECT

DRAWING TITLE  
**NODE SPRINKLER SUBMITTAL**

SUBMITTAL NUMBER	<b>272422</b>	SHEET 4 OF 4	SIZE <b>B</b>
------------------	---------------	--------------	---------------