

# SUBMITTAL

**LENGTH:**

- 1000MM
- 1500MM
- 2000MM

**FITTING 1 TYPE:**

- JOHN GUEST PUSH FITTING
- UNION NUT WITH GASKET
- PIPE STUB

**FITTING 1 SIZE:**

- 1/2" NOMINAL
- 15MM NOMINAL

**FITTING 2 TYPE:**

- JOHN GUEST PUSH FITTING
- UNION NUT WITH GASKET
- PIPE STUB

**FITTING 2 SIZE:**

- 1/2" NOMINAL
- 15MM NOMINAL

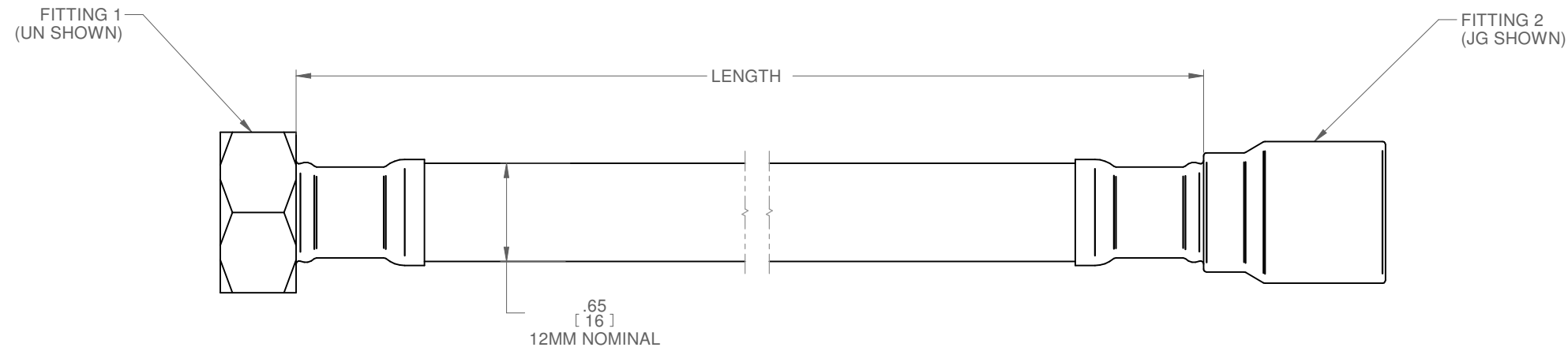

**FRONT VIEW**  
GENERAL CONSTRUCTION

THREAD TYPE:  
BSPP, G 1/2"

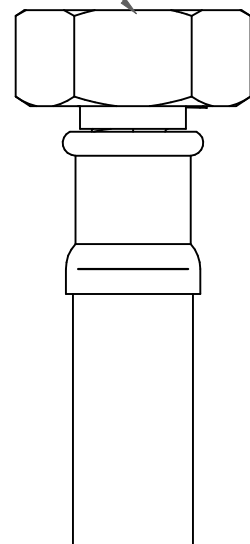

**UNION NUT**

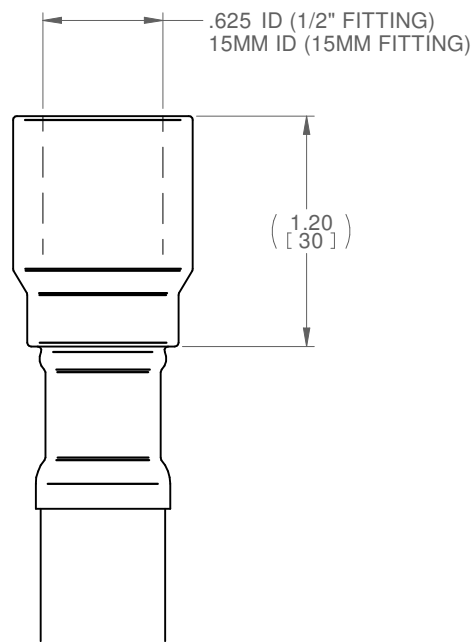

**JOHN GUEST PUSH FITTING**

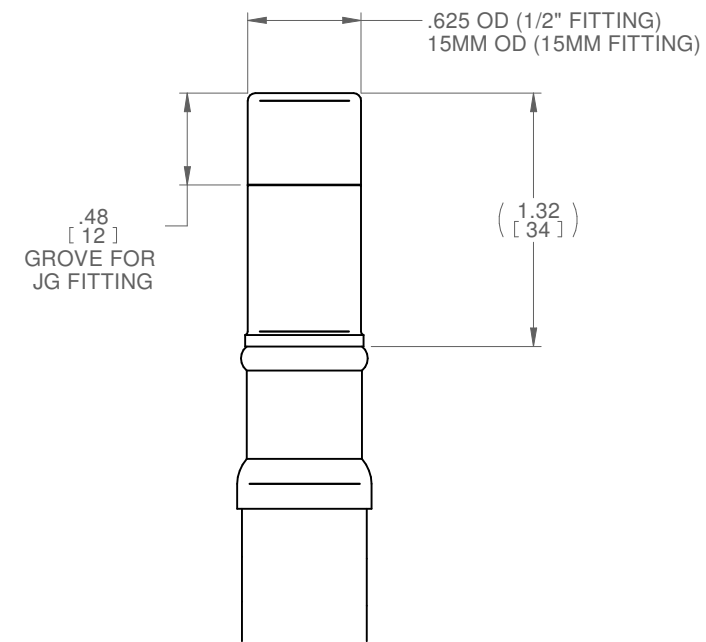

**PIPE STUB**

**CONSTRUCTION:**

- EXTERIOR RADIANT HOSE
  - o FLEXIBLE BRAIDED STAINLESS STEEL
- INTERIOR RADIANT HOSE
  - o PE CORRUGATED HOSE WITH EVOH OXYGEN BARRIER

**FINISH:**

- STAINLESS STEEL

**MECHANICAL SERVICE**

- MAXIMUM OPERATING PRESSURE AND TEMPERATURE FOR RADIANT HOSE
  - o 15 BAR (217 PSI) @ +80° C
- MAX OPERATING PRESSURE AND TEMPERATURE WITH JOHN GUEST FITTING
  - o 10 BAR (145 PSI) @ +23° C
  - o 7 BAR (101 PSI) @ +65° C

**ASSEMBLY AND INSTALLATION**

- ALL COMPONENTS SHOWN ARE FACTORY ASSEMBLED BY PARC UNLESS OTHERWISE NOTED
- ALL INSTALLATION BY OTHERS AND METHODS SHOWN ARE NOTIONAL
- (ASSY BY OTHERS): PROVIDED BY PARC, FIELD ASSEMBLED BY OTHERS
- (BY OTHERS): PROVIDED AND FIELD ASSEMBLED BY OTHERS

**NOTES:**

- DIMENSIONS SHOWN IN PARENTHESES ARE FOR REFERENCE ONLY (X.XX)
- METRIC DIMENSIONS SHOWN IN BRACKETS [X.XX]
- PRODUCT FINISH MAY VARY IN TONE, GLOSS AND TEXTURE; VARIATIONS ARE WITHIN PARC QUALITY STANDARDS
- TBC: DETAILS TO BE CONFIRMED

REV	DATE	DRAWN BY	CHECKED BY
A	2021-10-19	AS	JAC

ALL DIMENSIONS IN INCHES UNLESS OTHERWISE SPECIFIED

TOLERANCES UNLESS OTHERWISE SPECIFIED	LINEAR	ANGULAR
X.X ± .06	X.XX ± .03	X ± 1
X.XXX ± .01	X.XX ± .25	DEGREES

PROJECT  
**RADIANT HOSE**

DRAWING TITLE  
**STANDARD SUBMITTAL**

SUBMITTAL NUMBER	<b>273694</b>	SHEET 1 OF 2	SIZE <b>B</b>
------------------	---------------	--------------	---------------

